



中国环境与发展国际合作委员会

China Council for International Cooperation on Environment and Development

Special Policy Study

Environmental Issues and Countermeasures Facing New Rural Development in China

(English Version)

**Special Policy Group
on Environmental Issues Facing New Rural Development**

5th Annual General Meeting of CCICED

2006.11.10-12



中国环境与发展国际合作委员会

China Council for International Cooperation on Environment and Development

Special Policy Study

Environmental Issues and Countermeasures Facing New Rural Development in China

(English Version)

**Special Policy Group
on Environmental Issues Facing New Rural Development**

5th Annual General Meeting of CCICED

2006.11.10-12

This Study is supported by

Department of Environmental Science & Engineering,
Tsinghua University, Beijing

Leader Researcher

Ji-ning CHEN, Vice President of Tsinghua University, Professor

Researchers

Peng-fei DU, Associate Professor, Tsinghua University

Xia HUANG, Professor, Tsinghua University

Guang-he LI, Professor, Tsinghua University

Wen-jun LIU, Associate Professor, Tsinghua University

Xue-hua LIU, Associate Professor, Tsinghua University

Hong-tao WANG, Professor, Tsinghua University

Xiang-hua WEN, Professor, Tsinghua University

Jing WU, PhD., Tsinghua University

Xu ZHANG, Associate Professor, Tsinghua University

Content

1 INTRODUCTION	1
2 ENVIRONMENTAL ISSUES FACING NEW RURAL DEVELOPMENT	1
2.1. WATER SHORTAGE AND LOW DRINKING WATER SAFETY IN RURAL AREAS	1
2.2. LAGGED RURAL INFRASTRUCTURE AND POOR SANITATION.....	5
2.3. A MASS OF WASTE FROM FARMING AND LIVESTOCK FEEDING AND LOW EFFICIENCY AND PROFIT OF WASTE UTILIZATION	8
2.4. WATER AND SOIL DEGRADATION, AND ECOSYSTEM DEVASTATION	10
3 CASE STUDY IN NEW RURAL DEVELOPMENT	13
3.1. CASES OF SAFE DRINKING WATER SUPPLY IN RURAL AREAS.....	14
3.2. CASES OF RURAL HOUSEHOLD REFUSE DISPOSAL AND LIVESTOCK WASTE TREATMENT.....	22
3.3. CASES OF AGRICULTURAL WASTES DISPOSAL	31
3.4. CASES OF RURAL HOUSEHOLD WASTEWATER	36
3.5. SOIL AND WATER CONSERVATION IN WUHUA COUNTY	46
4 COUNTERMEASURES FOR NEW RURAL DEVELOPMENT	47
4.1. INTENSIFYING POLICY AND FUNDS SUPPORTS	47
4.2. PARTICULAR CONSIDERATION OF LOCAL CONDITIONS	48
4.3. PRIORITY OF DRINKING WATER AND PUBLIC SANITATION IMPROVEMENT	49
4.4. FOCUS ON FARMERS' AWARENESS AND RESPECT OF THEIR WILLINGNESS	49
4.5. FULL UNDERSTANDING OF CURRENT ACCOUNT AND TARGETED DEVELOPMENT	49
4.6. UTILIZATION EFFICIENCY AND PROFIT IMPROVEMENT	50
4.7. FOCUS ON LOW-COST MEASURES AND TECHNOLOGIES.....	50

1 Introduction

This report is organized into three sections, each section dealing with a specific aspect of the study.

Section 1: Environmental issues facing New Rural Development

Section 2: Case study and mode analysis for New Rural Development

Section 3: Countermeasures for New Rural Development.

Experiences of several projects have laid sound ground for this research, including, national key science and technology specialized project Non point pollution control in Dianchi Lake catchments, Water environment protection plan and demo in Miyu reservoir catchments, Design for water environment protection in Huangtukan Village, Miyun County, Sustainable landfill for household refuse in Wangzhuang Village, Miyun County, Safe drinking water technology in rural areas, and Research on Sustainable Development in China's Rural Areas etc.

Given the fact that little information is available for strategic research of new rural development, this project has conducted a survey on energy structure and environmental protection in rural areas in Northern China, covering 15 provinces (including Beijing and Tianjun). More than 300 students took part in the 2-month survey. By interviews and questionnaires on farmers and relevant officers, we collected a large quantity of first-hand information. This report is the outcome of these efforts.

2 Environmental Issues Facing New Rural Development

Since the implementation of the 'Reform and Opening-up' policy in 1970s, rapid development of intensive agriculture and profound transformation of rural household pattern, together with increasingly tremendous impact of urbanization and industrialization, have considerably deteriorated ecological and environmental degradation in rural areas. This has exerted marked negative influence on rural landscape, human health and life quality promotion of rural residents, and set up insurmountable challenges to target the objectives of new rural development. In sum, there are four issues in terms of New Rural Development.

2.1. Water shortage and low drinking water safety in rural areas

Water shortage and poor water quality are the most dominant threats to drinking water safety in rural areas. Due to long-existing distance between rural and urban socio-economic development, the government has attached much less importance to water supply safety in villages than to that in municipality and industries. Water shortage in rural areas is protruding. On the other hand, water pollution and various

waterborne endemic diseases are deteriorating due to lack of sufficient quality supervision on drinking water for rural residents and livestock, poor treatment facilities and low reliability of water supply, and low efficiency and poor quality of water devices in rural areas.

2.1.1. Water scarcity

China is rather abundant in water resources, and the total volume of China's water resources takes the 6th place in the world only after Brazil, Russia, Canada, the USA and Indonesia. Because of its largest population in the world, however, China's available water resource per capita, which is 2300m³, is merely 1/4 of the average level in the world and is much less than that in most other countries. Given the fact of uneven spatial and temporal distribution of water resources, water-consuming industrial structure and crop structure, and undeveloped water-saving technologies, etc. water shortage in China is tremendous, especially in rural areas. Statistics show that annual water shortage of agriculture is 30 billion m³, and that every year there is 80 million people and 60 million livestock in rural areas have difficulty in access to drinking water in China.

Due to dual socio-economic structure between urban and rural areas, rural water supply is not so prior as urban and industrial. Presently, the coverage of drinking water supply is less than 40%. Only 14% of all villages have necessary facilities and services, not mention their poor quality, low efficiency and low reliability for water supply. In some regions with abundant water resources, water supply safety also could not be secured, since villagers have to draw water directly from lakes, rivers, ponds or shallow wells without water supply equipment. In other regions which are in short of water seasonally, the villagers have to draw water or buy drinking water from a great distance. In recent years in particular, water scarcity in rural areas is becoming much severe due to global climate change and prevalent drought across the whole county.

2.1.2. Poor water quality

Water quality safety is very important for rural areas, since it bears a close relationship with public health problems. In some areas, drinking water can hardly comply with the national standards for drinking water quality, and waterborne endemic diseases especially those resulting from high-fluoride, high-arsenic and saline water, have adversely affected public health. These problems have long attracted public attention, and are urgent to be tackled. Statistics reveal that 25% of rural population is drinking polluted water, and this trend is set up to continue. Altogether, there are 300 million rural people who do not have access to safe drinking water. Among them, 190 million people are drinking water containing excess hazardous substances, more than 63 million suffered from high-fluoride drinking water, more than 38 million using saline water for drinking, and 2 million are affected by high-arsenic water. The population who are drinking water containing more than

2mg/L fluoride is almost 40% of the total population who are suffered from waterborne endemic diseases.

With an increase of industrial and domestic wastewater discharge and of pesticide and fertilizer application, many rural water sources are polluted and pollutants it contained surpass national standards violently, not only in the aspects of aesthetic and bacterial indexes, but also more and more chemical and even toxicological indexes. Widespread deterioration of water quality and resulting high content of microorganisms and organic pollutants are threatening the drinking water quantity, water quality and sanitary conditions of rural population since they draw water directly from water courses, lakes, reservoirs, ponds and shallow wells yet without purification and disinfection. The pollution of Kuisui River in Anhui province, for example, has caused water shortage to 250,000 people living on the riversides.

Close to pollution sources or polluted by industrial wastewater, existing shallow wells and water cellars in rural areas are most in poor sanitary conditions. Toilets, cesspools, barnyard and wastewater ditches are often found within a distance of 10m around many wells, and some wells are even polluted by industrial wastewater. A monitoring program of 234 water supply facilities in Tonglu, Zhejiang province shows that only 8.81% of the samples complied with the bacterial standards. Another monitoring program in 69 towns and villages in Beijing, Tianjin and Tangshan cities reveals that more than half of the ground water samples and drinking water samples overrun the nitrate standard.

2.1.3. Waterborne endemic disease

Poor quality of drinking water has an extremely adverse influence on human health of rural residents, and waterborne endemic diseases, and infectious diseases relevant to water sanitary break out frequently.

Villagers with a long-term ingestion of high-fluoride drinking water across North, Northwest, Northeast China and the plain of Huanghe, Huaihe and Haihe River in China, suffer from dental and skeletal fluorosis, and even paralysis. These diseases are very hard to cure and always exert heavy burden on rural families and thus lead to poverty. In these areas, dental fluorosis and kyphosis often directly affect enrollment in school and army, employment and marriage. The height of some villagers is only 0.8~1.4m who suffer from great pains both physiologically and psychologically. Arsenic pollution of drinking water spreads across Shanxi province, Ningxia province, northwest of Xinjiang province and some areas in Northeast China. Neimenggu and Guizhou provinces are also newly reported to have arsenic polluted drinking water. The population affected by high-arsenic water in Neimenggu, Shanxi, Xinjiang, Ningxia and Jilin is about 2 million in the recent several years. An investigation in 111 villages in 8 countries in Zhejiang province showed that 47.37% of the investigated population was exposed to arsenic. Long-term ingestion of high-arsenic drinking

water is damaging human health and often leads to cancer at several sites, particularly skin, bladder and lung. Saline water mainly appears in North China and the coastal East China, which gives rise to detectable taste in water and thus can not be drunk directly. Long-term ingestion of saline drinking water may lead to a disorder of stomach and intestine and poor immunity.

Serious infectious disease such as typhoid, paratyphoid and cholera broke out in some areas, while cancer morbidity keeps high in a few places. A higher mortality is observed among the residents due to long-term consumption of polluted water in Huangmengying village of Zhouying country, Shenqiu county of Henan province which lies on the side of Shanying River, the largest branch of Huaihe River. Residents along the Le'an River in Jiangxi province, in the Xiditou village and Liukuaizhuang village of Xiditou Town in Tujian city, and in Longling village of Hua county in Shanxi province abstract shallow ground water within a depth of 50m for drinking, which causes a high mortality of cancer. People in 15 cities of Guangdong province suffer from dental fluorosis, concretion, and other diseases in skin and thyroid gland in some villages. Newborn babies are not well developed as a result of the long-term ingestion of water with high radioactivity and hazardous minerals by local people in Shaoguan and Heyuan cities.

Due to insecure drinking water, schistosomiasis has revived in recent years and tends to increase. The affected area covers 110 counties in Hu'nan, Hubei, Jiangxi, Anhui, Jiangsu, Sichuan and Yunnan in the watershed of Yangtze River, and has a affected population of 60 million. The plain of Yangtze River and Han River, the catchment of Dongting Lake and Poyang Lake, the flood plain of Yangtze River and the mountainous areas of Sichan and Yunnan provinces are seriously affected. In these areas, residents draw water directly from channels, ditches and rivers, while toilets and cesspools are simply built and in poor sanitary conditions. Investigation in Anhui province and some other areas showed that improvement in rural drinking water supply and hygienic toilets could decrease snail infection by 40~60%.

2.1.4. Alternatives of appropriate technology and water supply modes

Nowadays, drinking water treatment for source water containing high-fluoride, high-arsenic and saline water has been the priority, which is targeted to be solved during the 11th five-year period by the government. However, drinking water improvement in China has been influenced by many factors, such as management institution, financing, technology alternative and water supply modes, and education and living pattern of farmers, etc.

Villagers in China are characterized by scatter settlement and low household income which restricted water supply in rural areas greatly. Recently, decentralized water supply covers about 66% of the rural population, and most of the projects are small in scale and have to be built, managed and used by single household. The

coverage of centralized water supply with a capacity more than 20m³/d is merely 34% of the rural population, that more than 200m³/d is only 14%, and that more than 1,000m³/d is even less than 2%. Rural water supply engineering projects are very small and diffuse in scale, and have to deal with problems of poor facilities and low finance ability in rural areas, which are very critical to choose appropriate capacity of centralized water supply facilities.

2.2. Lagged rural infrastructure and poor sanitation

Basically, there is no ‘environmental infrastructure’ in most rural areas in China, even in a few areas with certain, environmental infrastructure there is outdated. Chinese countryside has long been characteristic of ‘dirty and mess’, and poor environment and sanitation because of arbitrary discharge of household refuse, human and animal feces, crop residues and household wastewater.

China has 0.8 billion farmers, and every farmer discharge 220 kg refuse, 500 kg feces and urines, and 1300 kg wastewater per year. In the condition of traditional rural economy, refuse and wastewater can be recycled fully by returning into fields or else. However, with the rapid socio-economic development, rural economy is not pure rural any more. Industrial community circulation has gradually penetrated into rural economy, and in some areas, industry has substitute agriculture as the major income source of farmer household. Economic transition has exerted two profound influences in rural household refuse. On one hand, it increases the structure complexity of rural refuse with increasingly consumption of industrial products. On the other hand, traditional circular path of rural household refuse has been cut with the change of production and consumption pattern of rural residents.

Rural wastewater refers to water discharged in the process of washing, bathing and from some sanitary devices, such as flushing lavatory, etc. Lack of rural wastewater monitoring and statistic data, it is very difficult to evaluate the quantity and quality of rural household wastewater. Basically, rural household wastewater characterize of low discharge, relative high content of organic matter, large daily variation coefficients, and hysterical discharge. Except for a minority of developed cities, there is no household wastewater equipment in wide rural areas in China, and wastewater is discharge arbitrarily which is hotpot of mosquitoes and flies and spread infectious disease, hence dominant factor of rural environmental sanitation.

2.2.1. Rural household refuse

With the improvement of rural life quality, farmers have discharged much more refuse than before. Investigation by Tsinghua University reveals that rural household refuse in different regions is quite different. In some areas rural household refuse discharge is as much as or even more than urban refuse. Daily rural household refuse

discharge in Shunyi (Beijing), Dunhuang (Gansu), Longkou (Shandong), Linqi (Shandong) and Zunhua (Hebei) is 0.4~2kg. Mostly, there is no refuse collection and treatment equipment in these areas, but some villages require rural household refuse be put on certain place.

Totally, it is estimated that there are 180 million tons rural household refuses every year in China, mostly pile up in the open air. Among them, non-degradable inorganic matter will persist in the long run, while putrefactive organic matter will be degraded by putrefactive bacteria, and emission filter fluid, which make it a good place to breed mosquitoes, flies, bacteria, virus, and hence important indirect or direct pollution sources of waters.

Compared with urban household refuse, rural household refuses contain less meal remains, much more vegetable waste and crop residues, less abandoned household articles, such as plastics, glass, papers, less toxic articles, such as batteries, oil paint, and makeup, but more pesticide remains, and more earth in ashes. As a result, it is not cost-effective to treat urban and rural household refuse simultaneously. However, there is no specific refuse transportation and treatment system in most rural countryside, and field, roadside, waterside and dry rivers become natural dustbin. Only in countryside in developed regions or in the suburb of big cities, rural household refuse can enter treatment system of urban household refuse and be disposed properly.

2.2.2. Rural household wastewater

With promotion of Toilet Improvement in rural areas, problem of domestic wastewater stands out. Results indicates that daily household water usage ranges from 20 L to 400 L, and daily water usage per farmer is 29-35L, which came from continuous sampling monitoring by Tsinghua University in the neighboring of Dianchi Lake, Yunnan province. It also reveals that Chemical Oxygen Demand (COD), Total Nitrogen (TN) and Total Phosphorus (TP) per person per day are 29.1g, 0.4g and 0.46 g respectively. Investigations on mountainous village in Miyun County in Beijing and Jiulongjiang Village in Fujian province show that pollutants concentration in wastewater are relative higher, and all indicators has a high daily variation range. Statistical data in 2002 shows that national daily discharge of rural household wastewater amounts to 3.20 million tons, and includes 2831 thousand kg TN and 266 thousand kg TN. Due to inadequate wastewater treatment equipment in rural areas, rural household wastewater are mostly discharged directly to waters without any treatment.

2.2.3. Rural sewage system

Presently, there is no drainage system in rural areas, and there is no systematic planning for the collection and discharge of rain and wastewater in rural areas too.

Some villages have simple drainage ditches and some developed areas have constructed drainage system. All drainages in rural areas are all combined systems. So-called drainage in most villages is natural ditches or flood discharge trenches. An investigation taken by Tsinghua university indicates, 20%, 58%, 23%, 2% and 30% percent of farmer household in Beijing, northeast area (Gansu and Ningxia), north China (Shandong and Hebei) and Shanxi discharge rural wastewater into water environment arbitrarily. In Shanxi, there is another 89% of farmer household discharge rural wastewater into outdoors water channel. In some developed areas, some village constructed public drainage pipe to collect wastewater, for example in Beijing, 22% of farmer household use rural drainage system, but wastewater in those pipes will enter rivers and lakes directly without any treatment.

Most drainage systems are just open channel, and a few of them have a cover. Wastewater is discharged into nearby ditches and enters waters directly without any treatment, not mention rain. Due to inadequate management of rural sanitation or life habit for a long time, farmers tend to dump agricultural waste or household refuse into ditches, which makes ditches blocked, and wastewater spill over. This degrades ambient environment greatly.

2.2.4. Financing and operation for rural environmental infrastructure

Rural infrastructure is the premise of new rural development, which plays a very important role in poverty abatement, life quality improvement of rural residents, difference mitigation between cities and villages, production capacity promotion of agriculture and environment protection.

Shortage of capital has long restricted rural environmental infrastructure construction in China. By now, rural infrastructures construction is supported mainly by fiscal input of central government, collectivity input, farmers' self-financing or labor. However, all agricultural and rural infrastructures only occupy 8 percent of total national infrastructure construction investment and tend to decrease in recent years. Rural environmental infrastructure is characteristic of small-scale, diffuse, scarcity of practical technology, costly operational cost, low profit, poor construction condition, long duration of construction engineering. However, traditional market financing method for environmental infrastructures, such as BOT, PPP and BOO, etc., is developed for large-scale and high-profit project of urban infrastructure with government support, and is not able to solve the problem of financing of rural environmental infrastructure. Furthermore, existing infrastructure is confronted with a good many problems, such as shortage of maintenance and operation, due to capital scarcity and weak collectivity. Many dams, reservoirs, ditches which were built in 1970s, have been spoiled and can not be operated lack of maintenance and repair.

It is calculated that in the future 10 years capital demand for rural infrastructure is 200-300 billion yuan per year, which is in violent conflict with poor capital supply.

To solve these problems, it is imperative to strengthen research on financing mode of rural infrastructure.

2.3. A mass of waste from farming and livestock feeding and low efficiency and profit of waste utilization

With rapid development of farming and livestock in China, crop residues and animal wastes have increased year by year. Increasing intensive development of farming and livestock cut the close connect between farming and feeding as well as agriculture and pasturage. Without efficiency utilization, a mass waste pile up, are deserted, or are set on fire, which is totally a waste of resources as well as causes of soil fertility degradation, environmental pollution, and possible fire and traffic incidents. This is quite adverse to ecological environment and physical and mental health of urban and rural residents. Waste from livestock production is 2.5-3.0 billion tons per year, while rate of waste returned to field is just 30-50%, and only 2-3% waste is used to produce to commercial organic fertilizer. Crop residues quantity per year is 0.78 billion tons, and more than 60% of it piled up or were set on fire arbitrarily without utilization or returning to field. In this sense, resource is converted into pollution sources, leading to severe degradation of rural environmental quality and rural pollution has become a dominant factor restricting rural sustainable development.

2.3.1. Waste from farming

China has abundant farming wastes, which is about 0.78 billion tons per year. Presently, important crop residues amounts to 20 kinds, including 0.23 billion tons rice straw, 0.22 billion tons maize stems, 0.1 billion tons stems and leaves of soybean and food grain other than wheat and rice, and 0.2 billion tons vegetable wastes, peanut and potato bines. Besides, there are a good many oilseed residues, spent grains, sugar beet residues, sugar cane residues, deposed sugar residues, clippings of food industry and plant waste, such as grass and leaves. Crop residues has a high content of organic matter, primarily fibrin and semi-fibrin, and lignin, protein, amino acid, colophony, and tannin, and has great potential to develop and utilize. From the point of view of energy, available crop resides amounts 0.28-0.35 billion tons. If gas generation rate is 0.47 Nm³/kg, it is calculated methane generation is about 85 billion Nm³ per year.

Low efficiency and benefit of biomass energy use has restricted recycle of agricultural waste to great extent. Biomass energy (wood and crop residues, etc.) has long been one of the most important energy sources in rural areas in China, which account for 57% of total household energy. However, it is very inefficient and dirty to burn woods and crop residues directly, since it will emission soot and ashes resulting in air pollution of human community. In 2004, 211.1 billion tons woods were used as

energy by farmers in China, while heat energy use efficiency is merely 10%. Excessive deforestation and combustion has led to severe ecological and environmental deteriorations, soil quality degradation, since it cut the path of organic material returning to field. On the other hand, although China had a history of utilizing agricultural waste as resources, there is few technology innovations. It is very difficult to industrialize the small quantity of products of low quality transformed from farming wastes. Furthermore, low efficiency and value of those products has disabled their competitiveness in market, which in turn will restrict the utilization of agricultural solid waste as resources

2.3.2. Waste and wastewater from livestock feeding

In past 20 years, livestock production in China has increased as an average rate of 9.9% accompanied by an acute increase of livestock wastes. In 2004, it is 2.8 billion tons waste came from livestock and poultry feeding activities, and it is projected to be 4.5 billion tons in 2010. Presently, however, only 30-50% of livestock waste has been returned to fields. Diffuse feces without safe treatment are threatening water source, environment and agricultural ecological safety by means of air pollution (which emission some odorous gas, such as H_2S , NH_3 and dimethyl dithiol), nutrients (nitrogen and phosphorus), microelement pollution, heavy metal pollution, residues of veterinary drugs, and pathogenic pollution.

Major pollutants of livestock waste are feces, and livestock feces and their decomposed outcome contain high content of solid organic materials and emission odorous gas. The former includes carbohydrate, protein, organic acid, enzyme, etc. and the latter includes ammonia, sulfured hydrogen, volatile fatty acid, hydroxybenzene, quinine, dithiol, etc. Intergrowth includes pathogenic microorganism (bacterium, epiphyte and virus) and parasites egg, etc.

Livestock wastewater is also an important pollution source for water environment and rural sanitation. It is estimated that Chemical Oxygen Demand (COD) from livestock husbandry has exceeded the sum of that from industry and municipal household. Presently, 80% of wastewater came from more than 14000 large-scale livestock feeding factories is discharged directly into waters. Also, livestock feces and wastewater came form diffuse farmers are mostly discharged or piled up arbitrarily without any harmlessified treatment.

Livestock wastewater contained large amount of feces and urines of livestock and poultry, feed residues, residues of veterinary drugs, heavy metal ion and pathogen, which is "Four High Wastewater", i.e., high content of ammonia nitrogen, phosphorus, organic matter and suspended solids. Presently, there are about 14000 large-scale intensive livestock feeding factories, and 80% of wastewater came from them is discharged directly into waters. Livestock wastewater has become dominant pollution

source for rural water environment, soil environment and groundwater. Furthermore, it makes things worse for most intensive livestock feeding activities aggregates in east China and or in the suburb of big cities with high population density.

Current livestock feeding pattern and scale, are roots of severe pollution of livestock wastes. In recent livestock feeding pattern, too much animals is confined in limited space, the increase rate is too high, waste discharge is in excess of environmental capacity, and livestock waste can not be reused or recycled properly because of simplified animal structure and the disconnect of farming and feeding. Most livestock feeding factories adopt outdated feeding process, for example, they don't separate feces and urines, they wash animal shades with large quantity water, they add illegal additive into feed and they waste many feed which is washed into wastewater, etc. This increase wastewater discharge and complexity of treatment, hence wastewater treatment cost.

Existing farming pattern is another significant reason for severity of livestock pollution. Organic matter, nitrogen and phosphorus in livestock waste are all nutrients crop demanded in growth as well as feed aquatic creatures' favorite. If agriculture follow tradition farming method, all wastes will be utilized and returned to soil. However, with the widely consumption of chemical fertilizer in rural areas, chemical fertilizer gradually substitute organic fertilizer and livestock waste have to discharge or be wasted without proper utilization.

2.4. Water and soil degradation, and ecosystem devastation

With dual pressure from agricultural pollution and urban pollution, problems of environmental pollution and ecological destruction are mixed together and spread across atmospheric, surface and underground environment, water and soil in rural areas in China are polluted ever-increasingly, water courses are silted up, water quality deteriorates, and the ecosystem is destructed. These affect life quality of hundreds of millions of rural people and even threaten their health.

2.4.1. Water environment degradation

Rural water environment in China is being threatening by three kinds of pollution. Firstly, surface water in rural areas receives diffuse discharge of pollutants from agricultural production, rural living, solid waste and wastewater from municipal and industrial wastewater, and scattered township-village enterprises, which gives rise to color or smell in waters and make them blacken and stink all the year round or seasonally. In 2003, 36% of organic pollutants entering waters came from rural non-point source pollution, and in watersheds which are most important to be controlled, rural pollution contributes to 40~70% of total nitrogen and total phosphate. Secondly, water bodies in rural areas are also important recipients of the discharge

from urban domestic and industrial wastewater. The strict environmental management and pollution control in urban areas makes the transfer of heavily-polluting industries from big cities to small cities and villages, which later cause serious pollution to local water environment. Thirdly, in recent days, wastewater discharge from township-village enterprises added up to 21% of total industrial wastewater discharge.

In addition, as most rural water bodies are the tributaries of large rivers and are not monitored, the lack of monitoring and management leads to more serious pollution in some areas.

2.4.2. Soil fertility decline and soil pollution

2.4.2.1. Decrease and degradation of cultivated land

In China, available cultivated land per capita is 0.1008ha, only 32% of the world average. Even if all the arable backup land is counted, it is still just 36% of the world average. Even more, cultivated land area in China is reducing these years. In 2003, cultivated land area is 1200 million ha, and has reduced by 5% during 1996-2003.

Another problem concerning cultivated land is severe soil degradation in China. The content of organic matter in the farmland soil of China is less than half that of European countries. Almost all the farmland in China needs extra nitrogen, and that lack of phosphorus and potassium is 1/2~1/3 and 1/4~1/5 of the total farmland respectively. A severe problem brought about by the long-term application of chemical fertilizer is the soil compaction and mineralization. This caused the continuous decrease of organic carbon in soil, which will finally threaten the safety of agriculture.

2.4.2.2. Soil pollution

An incomplete investigation in China showed that 10 million ha of farmland is polluted by pesticides, chemical fertilizer, wastewater irrigation, heavy metal pollution, and plastic membrane.

Firstly, Heavy metals such as mercury, cadmium, lead, chromium and arsenic, nitrogen, organochlorine and phenols enter the soil when farmlands are irrigated by wastewater, or pesticide and fertilizer are applied. The application level of chemical fertilizer in China is 368kg/ha, which overrun the upper limit of 225kg/ha to prevent possible adverse effects of fertilizer on soil and water proposed by developed countries. In some areas where agriculture is well developed, the application level is even higher. Excessive application of fertilizer not only reduces the production increased by fertilizer, but also leads to soil compaction and pollution and finally make it less arable. Pesticide consumption in China is 1.31 million tons and average dosage per agricultural land is 13.97kg/ha, which is once higher than that of developed countries. More than 30 kinds of organophosphorus pesticide, totally 200,000 tons, are used in China, among which more than 80% is of severe toxicity.

Wastewater irrigation is mainly applied in the north, i.e. the watersheds of Haihe, Liaohe, Huanghe and Huaihe, where water scarcity is severe. These hazards may enrich in the food and exert adverse effect to public health. It is estimated that 12 million tons of food is polluted by heavy metals, which causes a direct economic loss of more than 20 billion Yuan.

Secondly, agricultural film belongs to high molecular compounds and is quite refractory. The degradation period of these compounds is generally 200~3000 years, and furthermore toxic pollutants may leach from the agricultural film during degradation. Statistics showed that the remains of agricultural film were as high as 350,000 tons each year, and its residual ratio is 42%. This means that almost half of the agricultural film remains in the soil, which is undoubtedly a potential risk. 100% of farmers in Beijing, northeast area (Gansu and Ningxia), north China (Shandong and Hebei) and Shanxi desert used plastic onsite or throw them into refuse pile.

2.4.3. Decline of agricultural biodiversity and ecological stability

About 5,000 kinds of plants have ever been used as food by human being, among which 150 kinds become economic crops and 30 grain crops. Livestock and aquaculture products are all domesticated or bred from wild animals. China has a long history of agricultural development and is rich in agricultural biological resources, which are material foundation supporting the sustainable development of agriculture in both China and the whole world.

2.4.3.1. Species extinction when seeking high yield

Rapid growth of population and improvement of people's living standard demand a large amount food, and therefore it is an inevitable trend to popularize the specific high-yield species of crops and livestock. More than 50 species of paddy, soybean and wheat for each are presently popularized, more than 30 for corn, fruit, sweet potato and peanut each, 18 for cotton, more than 20 for pigs and 10 for cattle, sheep and horse each. However, the recorded or kept species are extremely abundant, e.g. 48,000 paddy species and 20,000 wheat species were kept respectively. The problem is that some species have disappeared before they are collected. Since 1950s, 40% of the vegetable species have disappeared. Miscellaneous grain crops have been discarded and some species such as millet, buckwheat and small beans almost become extinct. Some species of livestock, such as red cattle and downy goat in Jia county in Henan and domestic goat in Ningxia, have crossbred and degenerated in quality and some of them are even on the edge of extinction.

2.4.3.2. Simplicity, instability and low efficiency of agricultural ecosystem

Traditional crop species and crop rotation have been gradually abandoned with fast development of farming industry. Intensive and mechanized farming prefers a single crop grown in a large area, which is convenient for management and harvest.

This need makes the agricultural ecosystem more and more simple which reduce effective resistance of crops greatly. Normally the life of a single crop species with effective resistance is only 5~10 years.

The agricultural disasters often take place in a large extent with a great variety and a high frequency and result in serious damage. In the recent 10 years, the disasters in China have brought about a reduction of 40 million tons of grains every year, and the economic loss is estimated about several hundred billion Yuan. The indexes of land productivity, agricultural labor productivity, resources utilization efficiency and input-output ratio of the agricultural ecosystem in China is far less than those of developed countries. The agricultural structure among farming, forestry, animal husbandry, fishery and agricultural services should be adjusted, and the agricultural layout on unit land area should also be optimized.

2.4.4. Soil erosion

The areas subject to soil erosion in China add up to 49.216 million km² which equals to 51% of the total land area of the whole country, and each year 5 billion tons of fertile soil and 61.67 million ha of farmland are eroded. Among this, 182.16 million km² is eroded by water, and 1.88 million km² by wind.

Soil erosion takes place in each province all over the country. Take the watershed of Huanghe River for example. The long-term average of soil erosion is 37 million tons/km², that of soil erosion modulus is 5,000~10,000t/km² with the highest up to 50,000~60,000t/km². Each year 1.6 billion tons of sediment is transported to the downstream of the Sanmen Gorge, among which 0.4 billion tons silts the downstream water courses and the other 1.2 billion tons is further transported into the sea.

Serious soil erosion in the upstream areas of rivers carries away a large amount of soil, thins down the soil layer in the mountainous areas and coarsens the soil. The structure of the soil is thus disturbed and its water storage capacity is reduced and even lost, which will greatly reduce infiltration while increase surface runoff during storm. Furthermore the siltation of rivers and lakes is also severe, and the total siltation volume of all the reservoirs reaches 20 billion m³ since the establishment of China, which equals to 200 large reservoirs with a storage capacity of 100 million m³. The direct economic loss caused by siltation is estimated 10 billion Yuan.

In addition, soil erosion is the root reason for poverty in mountainous areas. Presently, there are 2 million poor people living in areas with severe soil erosion.

3 Case Study in New Rural Development

The Proposal of the CPC Central Committee for Formulating the Eleventh Five-Year Plan for National Economic and Social Development, adopted at the Fifth Plenary Session of the Sixteenth Central Committee, sets forth the historic task for

boosting new rural development. Since then, enthusiasm for New Rural Development abounds everywhere, and lots of bellwether come forth to building new countryside, which provide valuable experiences and modes for national New Rural Development.

3.1. Cases of safe drinking water supply in rural areas

3.1.1. Desalination project of Xinhe town, Pingdu city

The northwest area of the Xinhe town, Pingdu city is a coastal plain made up of the deposited alluvium from both seas and rivers. The elevation above sea level is below 10m and the alluvion is more than 30m, where the saline ground water contains high mineralization of 20~30g/L. When the ground fresh water level drops, the saline water is uplifted by the sea water and intrudes the fresh water through the quaternary sand layer from north to south, which causes water shortage to agriculture irrigation and consumption of human and livestock.

Special geographical location and geological conditions cause the scarcity of fresh water resources in this area. In 1985, a centralized water supply system with a capacity of 1,000m³ was constructed to provide water for 22 villages, which benefited the industries, agriculture and people's life in Xinhe town. However, after 20 years of operation, the facilities were out of maintenance and repair. Meanwhile the water demand of industries and agriculture has increased, which causes the continuous decline of ground water level and the increasing expansion of saline water intrusion. Water quality deteriorates to such a level that none of the water sources were suitable for drinking water supply. Water shortage strongly affected the life of more than 30,000 rural people in 32 villages and the operation of more than 20 enterprises in the whole town. Obviously, water became the limiting factor of local economic development.

In 2001, the governments of Qingdao and Pingdu cities decided to reconstruct the centralized water supply system in Xinhe town. As there were no suitable water sources in the territory of the town and water transfer was also not feasible, the focus of the project was to find appropriate water sources and finally desalination of saline water were proposed. After elaborate evaluation of various alternatives of water treatment technology, reverse osmosis was selected because it had been well developed, its treatment facilities were reliable, and also it was able to use local water resources and meet the urgent need of water demand. The disadvantage of reverse osmosis is that the operation cost and the resulting water price (¥3/m³) are relatively high, however it is still affordable at present.

After four months of construction, a new water source was built and six wells drilled. A clear well with a volume of 300m³ was built at the water supply station comprising eight houses. A set of desalination device, the desalination efficiency of

which is above 95%, and an electric transformer were also installed. Plastic pipelines were laid down and added up to 34,000m. The whole project cost 3.4 million Yuan, among which 1.0 million was financed by both Qingdao and Pingdu governments respectively, and the other 1.4 million was supported by Xinhe government and the enterprises that benefited from the project.

The water supply project operates very well and the water quality complies with the design standards. The project has ended the long history of drinking saline water of the 2.18 million rural people in 24 enterprises and 32 villages. After that, four large enterprises invested in this town and accelerated local economic development, among which an investor from Beijing financed 15 million Yuan and established the Jingping mining corporation with an annual output of 50 million Yuan.

3.1.2. High-fluoride ground water treatment project in Huaibei rural areas

The activity of ancient Huanghe River carries a large quantity of minerals containing fluoride to the areas of Fengpeitong, Xuzhou city and Suyu, Suqian city in Jiangsu province. In certain conditions, the minerals enrich in the deposit and finally contaminate the ground water. An investigation showed that 70% of the poor families were related to fluorosis diseases, and some families were suffering from both diseases and poverty. High-fluoride ground water made aquaculture infeasible, and in some areas no safe water sources limited investment.

After a detailed survey into many rural water treatment plants, a device was designed to remove fluoride and installed between the deep well pump and the pipelines. The device is a vertical pressure vessel and integrates the processes of water distribution, fluoride removal, filtration, purification, sedimentation, activation and regeneration and backwashing in one reactor. The whole process could be automatically controlled without field inspection except activation and regeneration of filter media. The process is shown in Figure 1.

The device adopts the upstream adsorption-filtration process, and the adsorption capacity and the water productivity per unit area is high. The process is advanced with a well-designed configuration and can be continuously operated for a long time. The effluent is of good quality and the water demand of backwashing is low, and furthermore the regeneration liquid can be reused. The device is space-saving and easy to operate and manage without sludge discharge, and its initial investment and operation cost is also low.

Field test was applied at the Liuyuanji waterworks, Feng county and Zhuadaxing waterworks, Suqian city in June 2003 and May 2005 respectively to remove fluoride from drinking water. The devices operated well without failure in the following two years. As long as the filter media is appropriately activated, regenerated and backwashed, the finished water looks clear, tastes good and fluoride can also continuously comply with the standard. The operation of the device is easy and can be

control automatically, and the cost is 0.1 Yuan per ton of water, which greatly satisfies the villagers. Without the device, Liuyuanji waterworks only provided water to 1,000 households, 3,000 people. After the installation of the device, 2,500 households and 8,000 people are supplied. The installation of the device in Zhudaxing waterworks also increased the coverage of water supply from 600 households, 2,000 people to 2,000 households, 6,000 people.

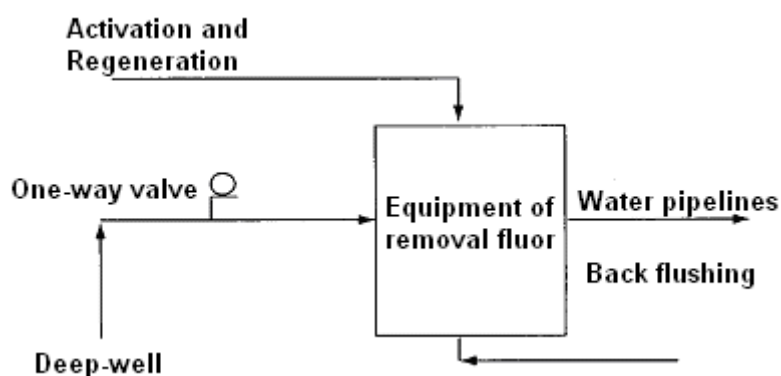

Figure 1 Flow chart of technics

3.1.3. Iron removal project in Gongwan village of Huaiyuan county, Anhui province

Gongwan village of Huaiyuan county, Anhui province lies on a hillside and has a population of 4,000. The people abstracted shallow ground water since ancient times, and always suffered from water shortage in dry seasons. In 2002, the authority of water resources drilled a deep well at a depth of 80m for local residents using the national debt, and since then the water quantity could meet the demand. However, water quality analysis showed that the iron concentration was as high as 2.1mg/L which is seven times higher than the national standard. Although clear and transparent when first abstracted from the well, the water turned to rust and smelly, and then got turbid due to the inside flocs after contact with the air for about ten minutes. The villagers were not willing to drinking such water and treatment was needed.

Taking advantage of the large land in rural areas and considering the three peaks of water demand at breakfast, lunch and supper time, natural oxidation is adopted to remove iron from the ground water. Water is pumped out of the well with high pressure and flows in the pipe to a reaction tank where it is divided into two streams by a valve. One stream, which is to be treated to remove iron, flows through a jet pump, where vacuum is formed and the air is sucked, to perform the first aeration. The aerated water then flows into a perforated pipe where it is sprayed into the reaction tank to perform the second aeration. The aerated water undergoes reaction, sedimentation and filtration in the reaction tank, and is finally collected into the storage tank for drinking water supply. The other stream out of the valve, which is

used for backwashing, enters the collecting pipes directly. During backwashing, the high-pressure water penetrates the filter beds and washes the deposit and flocs out into the drainage ditches.

The device and tank used to remove iron from ground water in Gongwan village only cost ¥ 20,000. Only one pump is needed in the well and the electricity consumption is thus almost half that of a set of treatment equipment. Water quality analysis showed that iron concentration decreases from 2.1mg/L to 0.2mg/L in the finished water, while alkalinity decreases from 579mg/L to 465mg/L. The pH value remains between 6.7 and 7.2, and the finished water can continuously comply with the national standards for drinking water quality (GB5749-85). The whole system is easy to operate and maintain, and the villagers are satisfied with it.

3.1.4. Iron and manganese removal project in Tangyuan county, Heilongjiang province

Tangyuan county lies in the east of Heilongjiang province, in the west of Sanjiang Plain and on the north side of Songhuajiang River. Local residents mainly uses shallow ground water for drinking, however the concentration of iron and manganese is always 20~100 times higher than the normal level. The shallow ground water is also polluted by pesticide and fertilizer and water quality deteriorates. Therefore it is an urgent problem for the government and the public to improve drinking water supply.

Tangyuan is a national level poor county, and therefore the government and the public could not afford much finance for improving drinking water supply. The water demand is generally low (about 10~20m³/h) at each single site in Tangyuan county while the concentration of iron and manganese is high (iron and manganese are 20~100 times and 5~30 times higher than standards respectively). Based on these facts, a gravity biological filter was constructed in Jianxin village, Heli town to remove iron from drinking water in June 2003, and the process performed well. The process combines small scale gravity biological filters with pressure filters, which ensures the water quality compliance with the national standards and at the same time reduces the treatment cost.

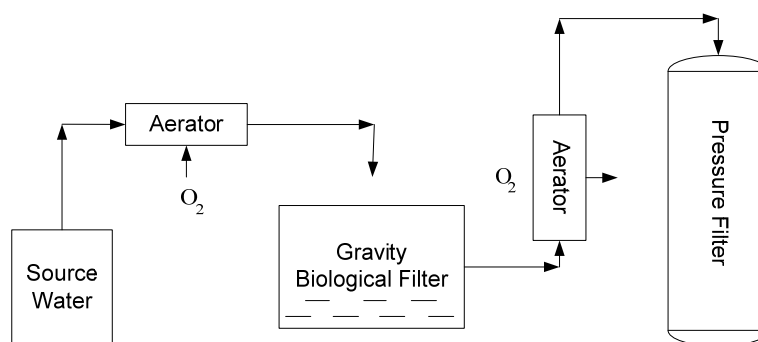

Figure 2 Flow chart of technics

The train of the process consists of water sources, aerators, gravity biological filters, aerators, pressure filters and the consumers (Figure 2). Water quality analysis after two months' operation showed that iron and manganese in the finished water complied with the national standards. However, the electric device in this process is a little complex, and it is difficult for the electricians and guards in the village to control them.

3.1.5. Water supply station in Wangguanzhuang village of Zhongwang town (Jinghai, Tianjin)

The source water of the water supply station is deep ground water at a depth of 350m, and the salinity ranges between 2.5g/L and 4.5g/L with fluoride violating the standard. The station adopts electro dialysis process to desalinate the source water, and the process is shown in Figure 3. After desalination, the mineralization of the finished water decreases to 0.1~0.25g/L.

The capacity of the water supply station is 2 tons per hour. The villages fetch water with prepaid tickets, and a ticket paid 0.3 Yuan equals to a barrel of 25kg water. Before the establishment of the water supply station, the only source water was slightly salty and tasted bad, which caused so much inconvenience to people's everyday life. Now the villagers are accustomed to use the "sweet" water supplied by the station and they mainly use the water for drinking and cooking. The water supply station and fetching water have become a part of the villagers' life. The electro dialysis system uses wound fiber as filter element to provide pre-treatment to the source water, and the filter element should be changed each half year. The whole system should be maintained and repaired each tow years. The water supply station and the water supply mode conform to the local conditions and have ended the long history of drinking saline water.

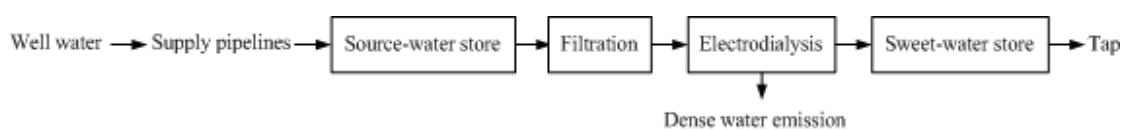

Figure 3 Flow chart of technics

3.1.6. Water supply station in Xiaohe village of Yanzhuang town (Jinghai, Tianjin)

The water supply station adopts the reverse osmosis process to treat the source water for wells with fluoride violating the standard. The source water first passes through the hollow fiber membrane and then enters the reverse osmosis unit. The process is shown in Figure 4.

The capacity of the water supply station is 0.5 ton per hour and the price for a

barrel of 20kg water is one Yuan. However, the village had been covered by pipelines before the establishment of the water supply station, and therefore the villagers were accustomed to use tap water. Although the water supply station provides “defluorination water” to the villagers at a reasonable price, the villagers are not aware of the harm of fluoride to health and are not willing to buy it. Therefore, the water supply station does not operate well and sometimes only three barrels were sold in a month.

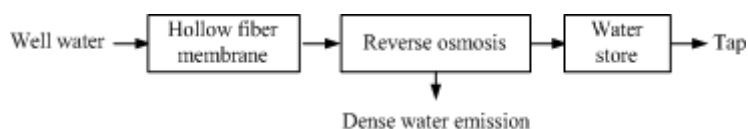

Figure 4 Flow chart of technics

3.1.7. Arsenic-removal water supply station in Shaziying village of Shunyi, Beijing

The water supply station in Shaziying village was a rural small-scale centralized water supply project implemented by the office of improvement of drinking water supply of Shunyi district. The project consists of the building of station (90m² brick workshop), water treatment facilities and pipelines, and totally costs ¥750,000 without counting the pipeline system. The water supply station serves 270 households, 930 people and its design capacity is 50 tons per hour.

The water supply station uses ground water as source water, several water indexes of which violate the standards of drinking water quality. After treatment, the finished water can comply with the standards. The station supplies water to the consumers at regular hours between 8 a.m. and 10 a.m. every day. The operation cost (mainly electricity cost) of the station is 8,000~12,000 Yuan and the cost of operation and maintenance are not directly paid by the villagers but by the village battalion. The battalion is in charge of the management of the station, and the electricians are in charge of the operation. Water quality monitoring and analysis is implemented by the Center for Disease Control and Prevention of Shunyi district.

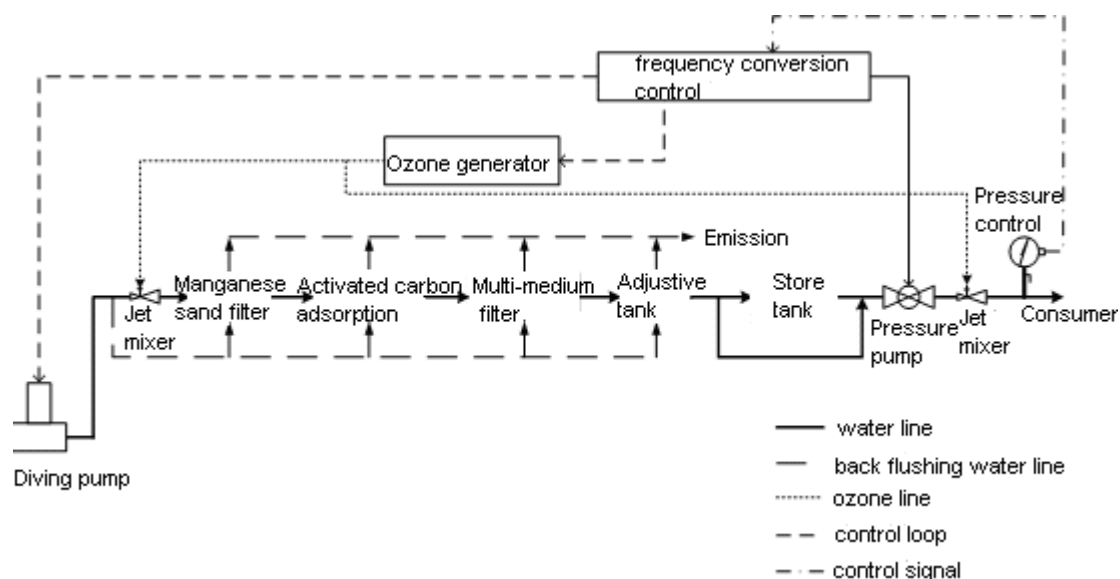

Figure 5 Water treatment flow chart in Shaziying village, Shunyi District, Beijing

3.1.8. Water treatment plant in Chashan town of Dongguan, Guangdong province

During the urbanization process, the economic structure of Chashan town of Dongguan, Guangdong province has shifted from traditional agricultural economy to industrial economy characterized mainly by processing materials supplied by clients. In order to meet the needs of water quantity and quality, a modern water treatment plant has been built with a design capacity of 250,000m³ per day. The plant uses Dongjiang River as the water source and applies the conventional treatment process, i.e. coagulation and flocculation, sedimentation, filtration and disinfection. Pre-treatment facilities (potassium permanganate and powdered activated carbon), thorough emergency response plans and online monitoring system are also established. The finished water complies with the national standards and is of better quality. The water supply mode in this town has realized the modern concept of the unified design of water supply systems between urban and rural areas.

3.1.9. Project modes of rural safe drinking water

Key factors limiting the construction projects of rural safe drinking water are management, technology and finance. Among them, management and finance are much more important.

Presently, safe drinking water engineering is implemented and administered by the Ministry of Water Resource (WMR). However, WMR's major task is to design, construct and manage water conservancy projects, and has less experience in managing drinking water quality, monitoring, relevant technology and process

selection, and relevant project construction and maintenance. In the long-run, it is inevitable that all drinking water affairs in rural areas will be integrated with that in urban areas, and all be managed by a single administrator, best choice of which is the Ministry of Construction (MOC) , so as to fulfill of simultaneous development of cities and villages. In the short-term, drinking water engineering construction and maintenance could be managed by cooperation of MWR with MOC and gradually all administration is to be transited to MOC. By this way, rural water supply will be boosted greatly by learning water supply experience in urban areas.

In terms of choosing and adopting suitable water supply scale and treatment technology, several factors should be considered.

(1) Centralized water supply system integrated urban and rural areas

In the plain areas such as the Pearl River delta and the Yangtze River delta, where economy is developed and the rural areas is centralized and lumped together with urban areas, centralized water supply system integrated urban and rural areas is proposed. Extending the urban water distribution system to rural areas can ensure the quantity and quality of drinking water and reduce the risk of equipment, operation and maintenance brought about by decentralized water supply. This mode can also promote the great-leap-forward development of rural water supply and eliminate the difference between urban and rural areas. Zhuhai, Dongguan, Shenzhen and some areas in Zhejiang and Jiangsu have witnessed the successful application of this mode.

(2) Water supply station for a single village or several villages

It is difficult to construct an integrated water distribution system to connect the rural areas with the urban areas when the villages are scattered. In such situation, water supply station can be constructed to supply the local area of a single village or several villages. In this mode, the operators are in charge of the operation of the station, and therefore ensure the quantity and quality of water supply. This is also the widely applied centralized water supply mode in most rural areas presently in China such as in Beijing, Tianjin and Shandong.

(3) Household water supply

In mountainous areas where the residents are too scattered, it is even difficult to provide centralized water supply at the village level. Thus household water purifier can be used to supply drinking water to one family or several families.

Selection of water supply considering local conditions is often a combination of various possible alternatives, which includes three modes. Firstly, centralized water supply system integrating urban and rural areas, which is preferable in the plain areas such as the Pearl River Delta and the Yangtze River Delta, where economy is developed and the rural areas is centralized and lumped together with urban areas. Secondly, water supply station for a single village or several villages which should be

adopted by regions with scattered villages difficult to connect with cities. Thirdly, household water supply is most suitable for areas in mountainous areas where residents are too scattered.

According to their financial sources, rural water supply projects are generally suggested to be classified into three types.

(1) government-led and consumer-financed projects could be adopted, when local governments in developed areas are willing and able to construct water supply systems. In this mode, the central government can promulgate policy guidance (such as water quality requirement and water treatment technology requirement) to regulate the construction and operation of rural water supply projects financed by local governments. The cost can be paid by the consumers or local governments to ensure regular operation and maintenance of water supply system.

(2) government-financed and consumer-managed projects could be adopted in most rural areas, where economy is not well developed. In this mode, the initial investment of water supply system should be financed by the governments. The presently adopted mode, i.e. the initial investment is financed by the central or local governments while the operation cost is paid by the consumers, is deemed feasible.

(3) government-run projects could be adopted in less developed areas where water quality problem is however serious. In these areas even if the governments finance the construction of water supply facilities, consumers could still hardly afford the cost of operation and maintenance. In such cases, the governments should be responsible for the whole projects construction as well their operation and maintenance, otherwise the safety of drinking water quality could not be ensured.

3.2. Cases of rural household refuse disposal and livestock waste treatment

3.2.1. Rural household refuse treatment

The rural household refuse was traditionally composted with livestock wastes or dejecta in Chinese rural areas. During the past two or three decades, the direct dumping or simple landfill became the major treatment measure for rural household refuse because more and more chemical fertilizers are used replacing the organic fertilizers.

According to a survey regarding the energy and environment of North China, the household refuse of most rural regions has not been treated harmlessly yet. In some suburb areas and economic developed countryside, the household refuse is mainly treated with the municipal solid waste. Taking into account the *status quo* of rural

household refuse treatment and the future demand of the New Countryside Building, this study proposes two major disposal modes for rural household refuse: centralized treatment and self-treatment.

3.2.1.1. Centralized treatment mode

Neither composting nor incineration is a good solution for rural household refuse treatment. The composting product of mixed household refuse commonly contains various agricultural pollutants due to the complicated components of original refuse and is unwelcome for farmers. Therefore, the MOC brings out a centralized treatment mode in which the wastes are collected by villages, where *ad hoc* garbage stations are set with specific transporters and assigned staff, and transported to the county centralized treatment plant for disposing. During the process of building the garbage stations and collecting household refuse, not only can the village environment be cleaned but also the farmers living there can be educated and increase their awareness of environmental protection. The centralized treatment mode is easy to manage and can take a quick effect, which is suited to the status quo of rural waste management. However, the current landfill plant in county is unqualified to meet the requirements of sanitary and safe disposal due to the following problems, as the low level treatment facilities, bad management, ineffective operation, shortfall of funds, and etc. In the meanwhile, it is also a problem to find a new land for building new landfill plant in the future since the current centralized plant is filled up, which can't be reused.

3.2.1.2. Self-treatment mode

Taking into account the features of current rural waste management, this study proposes to build a new small-size reusable sanitary landfill in villages, which is hopeful to become the major mode for disposing rural household refuse. This is a self-treatment mode which can address the problem of long-term land-occupation due to its small size and carry out the substance recycle.

During the past years, many researchers are studying to build the landfill as a small-size bio-reactor, which can accelerate the stabilizing process of garbage and decrease the generation of landfill leachate. Thus, it can be an effective measure for disposing rural waste to build such reusable reactor-landfill, which can be adapted in the regions where is sufficient of land resource, far from the centralized landfill plant with high transportation cost, and not sensitive to environment (e.g. water resource site).

1) Biological pre-treatment + anaerobic landfill + post-disposal

The stage of biological pre-treatment for rural solid waste refers to control water content of waste under the aerobic condition and to degrade the easily degradable contents within 20-60 days before loading the landfill. During this period, the disposed wastes mainly include food waste, some agriculture organic waste and a

little of paper. This pre-treatment can lead to an effective control on the generation of landfill leachate and biogas. During this pre-treating process, a great amount of water content has evaporated and only a small account of rest water is loaded in the landfill, which can not only decrease the landfill leachate obviously but also dilute the pollutant concentration and improve the water quality of leachate. Moreover, the volume of waste can be compressed by the pre-treatment process and the generation of biogas can decrease with less landfilled organic waste.

The landfill unit is a close landfill after pre-treatment. The stabilizing process of waste can be accelerated by reinjecting the landfill leachate and reduced to 5-8 years. During this period, the organic contents of wastes are degraded gradually. On the other side, the reinjection of landfill leachate can control the water content effectively and promote the pace of stabilization.

After stabilization, the next step is to excavate and separate the covered wastes. The sieved undegradable wastes such as textile, rubber, leather, wood, etc. can be incinerated; the big-size wastes such as blocks and building wastes can be used for backfilling or the landfill base; and the sieved stabilized fine stuff can be used as the cover stuff or nutrient soil. Figure 6 shows the process of technical line.

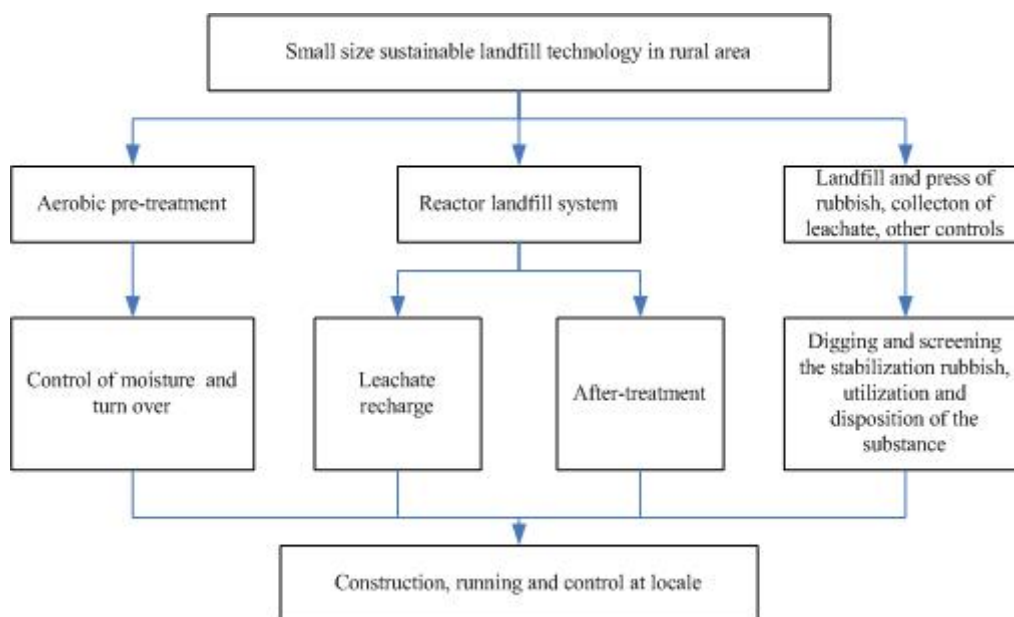

Figure 6 Flow chart of small-size landfill in rural area

2) Quasi-aerobic landfill + post-disposal

Quasi-aerobic landfill is a kind of landfill technology combining aerobic and anaerobic process, which is brought out in Japan firstly. It is to enlarge the size of exhaust pipes and sewers and to connect the exhaust pipes and leachate pipes based on the traditional anaerobic landfill. The gas can be induced into the inside of landfill by using “chimney effect” and create an aerobic circumstance around the surface layer,

collection pipes and exhaust pipes to increase the aerobic areas and accelerate the degradation of organic wastes; while the middle body of landfill where the gas can not reach is still under anaerobic circumstance. The reinjection of leachate can not only guarantee sufficient water for landfill layers, but also reduce the amount of discharged leachate and the polluting level. The quasi-aerobic landfill mainly includes a gas educating system, leachate collecting system, impermeable layer, storage structure, water catchment, leachate equalizing pool, leachate treatment system, and etc. This is a kind of landfill technology without pre-treatment stage, which is easy to operate and suitable to the regions where has no sufficient lands for landfill.

3) Policy supporting and financing

Although treatment cost of villages refuse is much lower than that of cities, it is in great need of financing support of central and local fiscal system. Financing support in developed areas should come mainly from local fiscal system, while that in developing areas should come mainly from national fiscal system.

3.2.2. Rural biogas technology

To produce biogas by using livestock wastes and crop straws has been regarded as a solution for addressing rural energy problems and preventing rural waste pollution. The biogas can be used centralized or separately in countryside. The separated system means to produce the biogas by the individual family itself while the centralized on means to produce the biogas for several family, or several houses, or villages.

(1) Case study of “Four-in-One”: Pengyang County, Ningxia

“Four-in-One” is a synthetic agricultural energy ecological system, cored with biogas-making and combing biomass pool, livestock pens, toilet and greenhouse in one system. Pengyang County of Ningxia has built 331 “Four-in-One” systems since implementing the national ecological agriculture program in 1998. This system combines crop planting and livestock feeding through the linkage of biogas-making.

According to the investigation of 10 pilot cases in southern mountain lands of Ningxia, a “Four-in-One” system with a land space of 200m² and a biomass pool of 8m³ can make an annual revenue of 5823 RMB. The detailed benefits are listed as following: providing cooking and lighting energy for 4-6 persons, which saves 3.6 ton coal consumption and 208kWh power consumption per year; averagely slaughtered 2.7 pigs per year with an income of 1728RMB; planting 2-3 turns irregular season vegetable with organic fertilizer produced from the biogas-making process, which can make a profit of 3401RMB (an income of 2941RMB from producing 2695kg high quality vegetable and 460RMB for using organic fertilizer instead of chemical fertilizer).

(2) Case study of modified “Four-in-One”: Beijing suburbs

Dongshan Village, locating in the mountain area of Pinggushan, Beijing, makes some modification for the southern “Four-in-One” system. Dongshan Village changes the greenhouse as a double-cropping field with peach trees and vegetable and adopts trickle irrigation technology with the water of biomass pool, which has made a maximum use of the lands of greenhouse. The daily produced biogas can provide energy for 3-4 persons.

According to the random investigation of 15 farmers, the implementation of the “Four-in-One” system has born good fruits. For instance, each group of peach trees can produce 1000kg high quality peaches per year. The income for selling peaches can reach 20,000RMB/year with good marketing channels. The farmer can slaughter 6-8 pigs and earn a net income of 3000RMB per year. For each modified “Four-in-One” system, the farmer can earn an income of about 25,000RMB/year which is 4000-8000RMB more than the regular plastic greenhouse. In the meanwhile, the farmer can reduce the cost for energy consumption by using the biogas and increase the net income. Table 1 shows the actual detailed income and expenditure for the modified “Four-in-One” system.

Table 1 Statement of income and expenditure of “Four-in-One” ecological system

Item	Income	Expenditure
Initial investment for each plastic greenhouse	—	20000 RMB
Initial investment for each biomass pool	Government subsidizing 3000 RMB	4000RMB
Purchasing peach saplings	—	1500RMB
Selling peaches	30000RMB/year	—
Feeding pigs	3000RMB/year	—
Coals for heating	—	1000RMB/year
Water and power consumption	—	250RMB/year
Pest control	—	150RMB/year

(3) Biogas generated from rural solid waste

In 2000, the total number of biogas users reached 7.55 million and the total volume of produced biogas was 22,600 million m³. It is projected that the number of new rural biogas projects can reach 4100 with a biogas capacity of 450 million m³ (equaling to 580,000 ton standard coal) and a treatment capacity for feces of 123 million ton in 2015.

It is important for improving rural energy consumption and ecological environmental protection to make good use of biogas. Thus, it should promote the scheme of producing biogas by rural waste in the New Countryside Building program.

In the meanwhile, it is also important to develop new technologies to address problems (e.g. unstable biogas-producing, high humidity and low heat value of produced biogas, eroded pipes, and etc.), to improve the current system, and to normalize the production procedure and management.

3.2.3. Synthesis utilization of livestock manure

3.2.3.1. Centralized livestock feeding in Shuangliu, Chengdu and Xinzhi, Chengdu

The livestock feeding industry in Shuangliu County of Chengdu is an example of circular agriculture. The number of specialized households for livestock feeding with an average output value of over 100,000RMB per year has reached about 5000. For instance, Kangzhuang Cattle Farm, which is a synthetic stock raising enterprise combining cattle raising, beef processing and selling, and cow dung utilization, commonly has over 1000 stocks of cattle and provides 500 beef cattle for Chengdu each year. This farm is an ecological circular agriculture. Firstly, the major forage for cattle is grinded and fermented straws, which is returned to the nature after cattle's digestion. This is an ecological circular process which prevents the pollution of straws. Secondly, the cattle dung can be used for mushroom planting and earthworm feeding after drying; the cattle urine and wastewater of slaughterhouse can be discharged to the biomass pool for producing biogas; and the effluent of biomass pool with high concentration of $\text{NH}_4\text{-N}$ can be used as the organic fertilizer for farmland.

Xinzhi Pig Farm is another distinctive example of ecological circular agriculture. The farm adopts dry forage for breeding and installs auto watering trough for each pigsty, which is a water-saving breeding. The pigsty is set with sewing floor then the swine liquid excrement can flow in the preembedded underground sewers through the slots; while the solid excrement is packaged and delivered to the ferment workshop to make organic fertilizer. This farm builds 3 packed biomass pools where the swine liquid excrement is fermented to produce biogas. The effluent of biomass pools is then channeled to farmland as fertilizer.

3.2.3.2. Synthesis utilization of livestock manure in Daheng agricultural ecological park of Nanping, Fujian

Nanping pig farm adopts solid-liquid separation – anaerobic biological technology to design an ecological circular raising system in terms of the characteristic of wastewater quality. This system contains pre-treatment, main treatment and substance reutilization subsystems.

① The pre-treatment system contains cleaning solid substance by human, grilling, solid-liquid separating, acidification pool, and etc. The solid-liquid separation device can make a good remove for the solid substance of wastewater, and the removing rate of COD_{Cr} and BOD_5 is 69.98% and 66.44%.

② The main treatment system contains upstream anaerobic ferment tower,

sedimentation and water-storage basin, aerated water-dropping oxidation ditch, and etc.

③ The substance reutilization system contains compost system, biogas collection system, and irrigation system with water from biomass pool.

This project has run into a good operation with stable operation and good water quality of effluent since April 23 of 2003. The quality of discharged water can meet the requirement of designed objectives.

3.2.3.3. Waste treatment and utilization in the pig factory of Nanhanji village, Fangshan district, Beijing

The pig factory of Nanhanji village is a village-run enterprise with a design capacity of 10,000 heads, however the productivity only reaches one fourth of the design capacity at present. The actual stock of the factory is 1,600 heads and the wastewater discharge is 20~30t/d. The main treatment process includes:

(1) Equalizing tank and preheating tank. Acidification and hydrolysis of the feces takes place in the equalizing tank to facilitate the succeeding anaerobic digestion. The equalizing tank can also regulate the flow rate of the whole process and 30% of the organics can be degraded before leaving the tank. Assuming the wastewater discharge is 70t/d, the equalizing tank needs an effective volume of 23m³, and the design effective volume is thus 24m³. The preheating tank heats the wastewater to a temperature slightly higher than that in the digester and its effective volume is 10m³.

(2) Anaerobic digester. The digester is of a volume of 373m³ and applies the Upflow Anaerobic Sludge Bed (UASB) process. The digester is built wholly on the ground to facilitate sludge discharge and management. The digester is a cylinder in shape with a diameter of 8m and a height of 10m. The volumetric rate of gas production is 1m³/m³·d and more than 80% of the influent COD can be removed.

(3) Gas stirrer. The gas stirrer is bought from UK and it runs twice a day with duration of 10min.

(4) Sludge storage tank. The design effective volume of the tank is 2215m³ and it is used to discharge the overflow and sludge from the digester.

The marsh gas project of Nanhanji village was launched in May 1997 and completed in October. After three months of test run, the marsh gas was supplied to 104 households living in high buildings and the canteen of the pig factory during the spring festival of 1998. The test run proved that the digester could supply enough marsh gas to the whole village (104 households in high buildings and 187 households in two-story buildings) for cooking. A family with three persons need to pay ¥60 each month for commercial natural gas on average, however the marsh gas only costs ¥30. The thermal value of marsh gas is 5,000-6,000kcal/m³ and is equivalent to that

of natural gas. The marsh gas station gains a profit of ¥240,000 from marsh gas, sludge and liquor without consideration of depreciation of equipment and infrastructure. Taking into account the operation cost of ¥110,000, the net benefit is ¥130,000.

3.2.3.4. Livestock waste utilization in Huaxing Sow Feeding Factory, Tianjin

This factory is a subgroup of Tianjin Xianghua company, which is located in Niudaokou Village in Baidi District. The factory has a constructed area of 20 thousand km², 50 pig stalls, a pig stock of 3000 heads and slaughtered sow of 7000 heads. Before the implementation of ecological engineering, Huaxing sow feeding factory wasted a lot of feces and urines, supply of which exceed farming demand nearby by far, and polluted environment severely. At the same time, it is not economic for factory itself since nitrogen output is much more than nitrogen input. As a result, feces and urines treatment has been bottleneck of development. Other problems existed included monotonous product structure, large amount of residues of veterinary drug, high energy cost for coal heating, and dirty, smelly and mess view, etc. To solve these problems, ecological engineering technologies were applied in factory reconstruction, i.e. to construct an ecological farming park to promote harmless production, to utilize bio-gas for heating and lighting which integrated farming with feeding, and to construct organic fertilizer factory to utilization feeding wastes and add value to products. The framework of ecological engineering sees Figure 7.

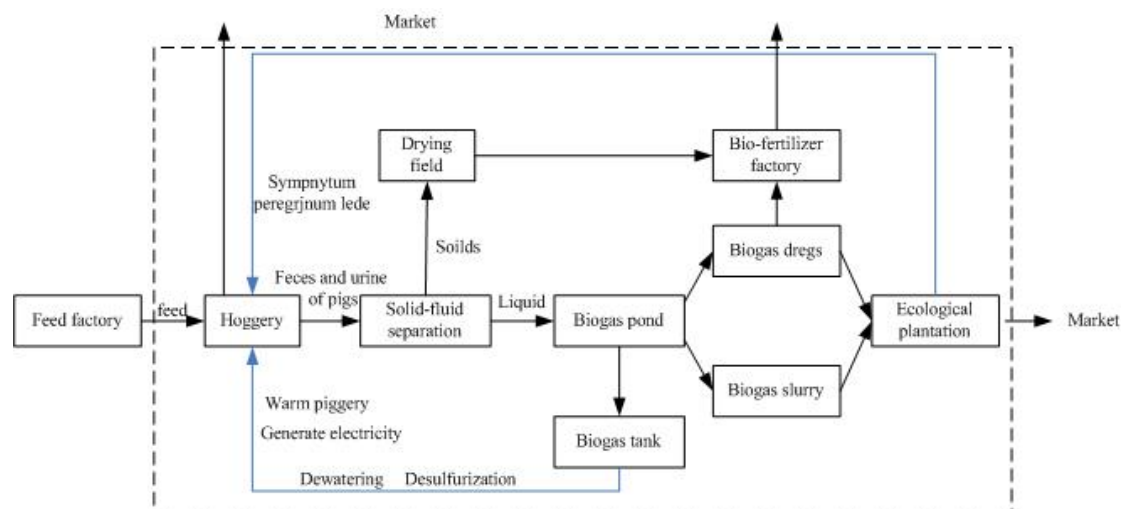

Figure 7 Flow chart of breed deject treatment and utilization in Xianghua ecological farm

3.2.3.5. “Three cleanse, Four utilizations” integrating farming with livestock feeding in Panjin

Xi’an experimental livestock station in Dawa county, Panjin city, has a sow population of 500 and sell 5000 pigs annually. To dispose annual livestock wastes of 300kg, this station dug a square pond in saline-alkaline lowland nearby. This pond is

0.5-1.0 m deep and square of it is 3.3 ha (1.0 mu). The other part of the lowland is converted into paddy field, square of which is about 27 ha (400 mu). Hyacinth and water fern *azolla filiculoides*, which can endure high nutrient in waters, are planted in the pond to substitute green or coarse feed, such as soybean, maize and vegetable and part of refined feed. By means of above measures, it is a circular concentrated feeding which connects farming with feeding within the station. Wastewater is returned into paddy field passing hyacinth pond, water fern *azolla filiculoides* pond, fish pond (2.6 ha, i.e. 40 mu). COD, BOD and TN removal reach 89.6%, 87.7% and 76.2%.

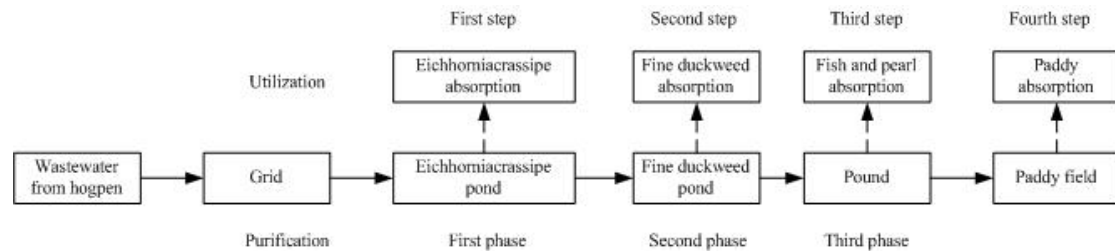

Figure 8 The mode of 3 phases purification and 4 steps utilization in Panjin

Experience to treatment wastewater from Xi'an experimental station is to resource utilization of wastewater, which should be integrated with wholly operation of the station, to form ecological circular concentrated feeding in combination with farming. Wastewater resource can be transformed into valuable input of pig factory and pig factory will adjust farming structure (to plant aquatic or paddy with better nutrient endurance and nitrogen fixation ability instead of maize or soybeans) and feeding structure (for example, to increase fish pond, to carry on three-dimensional fishery of fish and mussel and to increase hyacinth pond and water fern *azolla filiculoides* pond, etc.) necessarily to fulfill resource utilization of wastewater and form ecological circular feeding. To substitute green feed, coarse feed and refined feed by aquatic plant, farming and feeding are connected. By this way, nutrient can be circulated onsite, and no wastewater will be discharged. This system can dispose 3300 kg pig feces, 5000 kg pig urines daily which reduce consumption of chemical fertilizer and impact of agriculture on environment.

Furthermore, this project has a good profit. Before "Three Cleanse, Four Utilizations" was adopted, this station produced 108 thousand kg refine feed, 120 thousand kg green feed and had to buy 700-800 thousand kg green feed and 400-500 thousand kg coarse feed. Presently, the station can produce enough even more green feed and coarse feed to meet the requirements of feeding. Every year, fish yield is 50 thousand kg, and pearl 50 kg, which can reimburse fertilizer input.

3.2.3.6. Waste utilization mode of concentrated feeding

Concentrated feeding is very important in the development of rural livestock production. Animals confined in limited area will increase economic benefit, commercial waste utilization, control pollution discharge, and make management and control easier.

Concentrated feeding makes it possible to add value to energy product of livestock waste. One of important energy utilization of livestock waste is electricity generation, which has been successful in many developed countries. Some regions in China, such as Xiamen, Inner Mongolia, electricity generation engineering from livestock wastes is being studied and constructed.

Concentrated feeding should suit local conditions and should be prohibited strictly in important sensitive areas, for example water sources protection areas, etc.

3.3. Cases of agricultural wastes disposal

3.3.1. Compost and compound fertilizer production from various agricultural solid waste

To abate nonpoint source pollution in Dianchi Lake catchment, Tsinghua University constructed a demonstration project of compost of various rural solid waste and compound fertilizer production in Chenggong county, Kunming city. The demonstration project occupied 6000 m² land in Dayu village, in Dayu countryside, and it can treat 30 tons waste daily, including 12-15 tons vegetable waste, 3-5 tons flower stem or else, and 10-15 tons livestock wastes.

The demonstration aimed to produce compound fertilizer as well as waste treatment. The basic production process of compound fertilizer production includes:

Pretreatment system

Examination and ponderation: All wastes will be examined carefully before entering into the factory. Qualified material will be weighed and all quality related will be recorded.

Pile and airing: When materials arrive stocking yard, they will be piled up respectively according to the classification of putrefactive materials, non-putrefactive materials, household refuse, feces, and stuff. All materials will be dried in stocking yard to reduce moisture content and weight.

Selection and fragmentation: After necessary manual selection, all materials which can not compost, such as stones and plastics, will be removed. Removed materials will be transported to landfills. Farming solid waste will be fragmented and added feces and other materials, bacteria and structure adjustment medicine, etc.,

without fragmentation according to prescription.

Compost system

Initial fermentation: Mixed material will be transported into initial workshop to perform closed compulsory ventilated zymolysis. Because of high moisture content, it tend to produce an anaerobic environment and it is necessary to change storehouse considering fermentation process.

Secondary fermentation: Material fermented initially will be transported into secondary workshop to perform natural airing secondary fermentation, to reduce moisture content and age to a stable stage. If product of initial fermentation still has high moisture content, it is necessary to turn materials several times when fermentation to promote vapor of water. If product of secondary fermentation still has high moisture content, it is necessary to perform special treatment, such as air-drying to meet the requirements in the following steps.

Compound fertilizer production system

Compound fertilizer production: It is necessary to fragment and screen materials after second fragmentation. Materials remains (not aged enough) will be returned into initial workshop or second workshop to ferment. Materials which can not ferment will be disposed as waste materials to be landfilled. Materials after screen will be goods for compound fertilizer production. According to fertilizer prescription for different crops made by research 'Precise and Balanced Fertilization', chemical fertilizer and microorganism bacteria will be mixed with those goods and the mixture will be produced into microorganism active bacteria fertilizer, organic-inorganic compound fertilizer and special fertilizer. Produced fertilizer will be bagged and transported in storage.

Fertilizer selling: All produced fertilizer will be sold in the market. To demonstrate the validity of fertilizer, the product will be promoted in field experiments together with Precise and Balanced Fertilization.

3.3.2. Anaerobic methane engineering by using crop residues in Tai'an, Shandong Province

With the support of the Ministry of Agriculture (MOA), Beijing University of Chemical technology constructed anaerobic digestion equipment to make use of crop residues. The equipment has 9 reactors, a reaction volume of 450m³, and can consume 288 tons maize stems and 360 cattle feces per year. Among them, consumption of maize stems accounts for more than 60 percent of total dry materials. Methane yield of this equipment is 69120 m³, which can provide household energy for 180 households in the village. Also it will produce 104 tons organic fertilizer. This project has broke through two important technological problems, the one is to chemical pretreatment of maize stem which is very difficult to degrade, the other one is to heat

reactor to increase digestion temperature and efficiency by using solar energy, which makes the reactor can warmly digest wastes in spring and autumn, and hot digest in summer. Results indicate that, this system has a higher digestion efficiency and gas generation 1 times more than other anaerobic digestion systems.

3.3.3. Agricultural solid waste utilization

3.3.3.1. Energy and feed produced by crop residues

China has a variety and abundant resource of farming waste. Thus, it is urgent to make best of mass farming wastes and to promote biomass energy efficiency and benefit, which will resolve the conflict of demand and supply of feed, fertilizer, fuel and industrial material, as well as to protect rural ecological environment, boost sustainable development of agriculture in harmony with human welfare and environment. Its resource utilization and feed utilization will suit most rural areas.

However, problem of material circulation should be pondered over in the process of energy utilization of crop residues. When utilizing energy, other resource should be made best of, such as nitrogen, phosphorus, potassium, and organic matter etc. Energy and resource problems should be considered at the same time from the point of view of an integrated circulation and be traded off by means of cost-benefit analysis. Due to limit cultivated land, pure energy resource is not sustainable and part of nutrients contained in the crop residues should be returned into fields to secure soil quality and sustainable agriculture.

3.3.3.2. Household crop residues gasification technology

Gasification of crop residues is a heat-chemical transformation technology, and its basic idea is to heat crop residues under the condition of inadequate combustion, which make organic hydrocarbon compound with high molecular weight (HMW) pyrolyze and transform into combustible gases with low molecular weight (LMW), such CO, H₂, CH₄, etc. In the process of transformation, gasifying agent should be added, such as air, oxygen or vapor, and major product are mixture of combustible gas with N₂ and energy will be retained in the combustible gas as possible as it can.

Crop residues is sound material form heat-chemical transformation since its high content of volatile matters, little ashes, and easy to pyrolyze. Heat efficiency of crop residues is decided by element composition, moisture content and particle size of materials. Generally, the higher moisture content in crop residues, the more heat will be used for heat water and the less net heat value and net calorific value it produced in combustion. Too big crop residues block will lead to incomplete combustion which will reduce transformation efficiency of biomass energy. As a result, all crop residues should be dried and fragmented before they are added into reactor.

Domestic biomass pellet fuel stove can integrate gasification with combustion, that is to say, biomass pellet fuel can be gasified in the stove to produce combustible

gases. Combustible gases can be completely combusted at the endpoint of the stove. When gasification is over, remained coal can be combusted totally. This kind of gasification can function either continuously or intermittently. This stove is very suitable for cooking since quick flame and proper heat load of about 1500W, which is characteristic of high transformation efficiency, fuel flexibility, up-to standard pollutant emission concentration, low cost, and safety. The process of this equipment can refer to Figure 9.

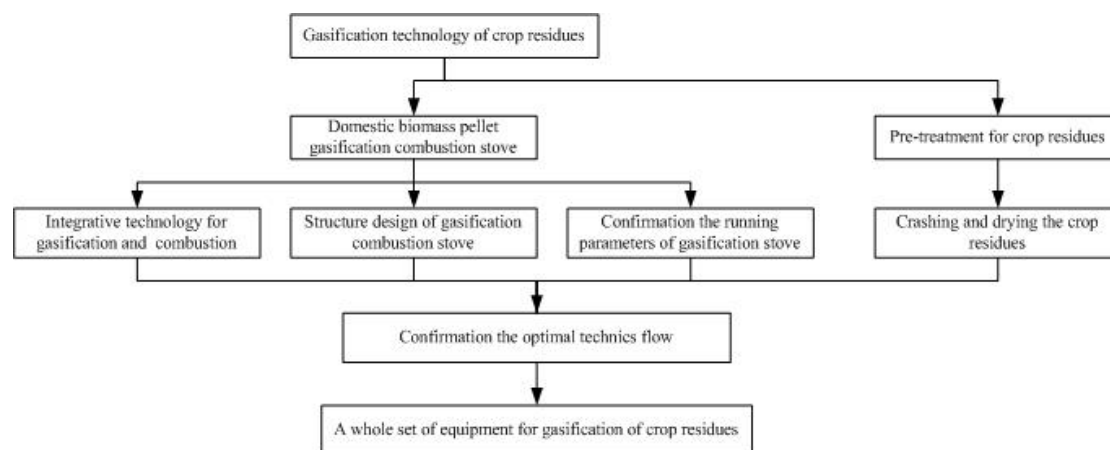

Figure 9 The illustration of crop residues gasification

3.3.3.3. Silage and microbial silage of crop residues

Feed utilization of crop residues can connect grain production with grain-saving feeding to promote their development. The development patterns accord with not only ecological principle of material circulation, but also ideas of economical society and sustainable agriculture. Besides energy utilization, feed utilization is another sound technology choice suitable for rural economy.

Silage of crop residues is to put green crop residues in the vault under sound condition, began anaerobic fermentation by means of microorganisms in the nature (in air, soil and crop residues), such as lactobacillus, etc., and finally transform carbohydrate into organic acid, such as lactic acid. This process will change crop residues into acid and savory feed with alcohol smell which livestock and poultry favorites. Since low p-H value and anaerobic environment restrict leaf mold activity, the feed is easy to be preserved for long periods.

Microbial silage is to add microorganism active bacteria into crop residues before put them into microbial silage vault. Under certain conditions, they will ferment in anaerobic environment and transform lignocellulose into saccharide. Saccharide will transform into lactic acid and volatile fatty acid, which makes crop residues acid and savory feed with alcohol smell which livestock and poultry favorites, which is easy to preserve for a long time. The technique process see Figure 10.

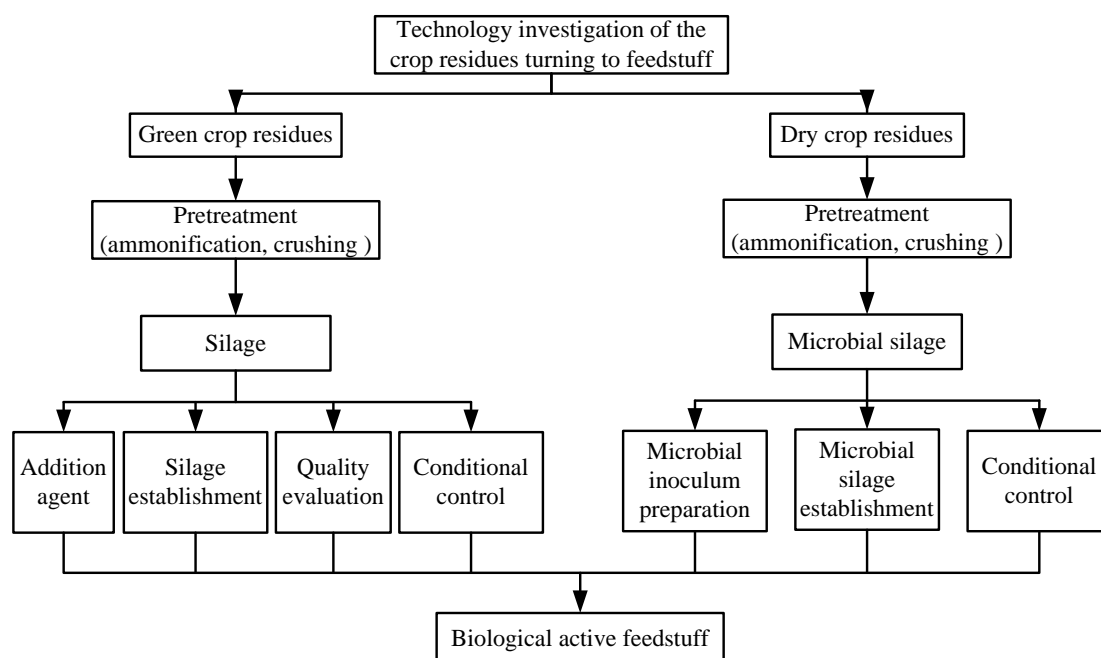

Figure 10 Progress chart of crop residues turning to feedstuff

3.3.4. Feed-Waste-Methane-Residues (Fertilizer) (FWMR) by using crop residues and livestock waste

Critical technologies in the ecological mode of FWMR of crop residues and livestock waste include anaerobic fermentation technology to transform lignocellulose into saccharide and then to transform saccharide into lactic acid and volatile fatty acid by means of silage or microbial silage, which are good and easy-preserved feed, high solids anaerobic bio-gas generation technology to reuse biomass energy in livestock wastes, aerobic fermentation technology to perform quick aerobic compost of fermentation remains and produce organic and inorganic compound fertilizer, aerobic fermentation technology for concentrated wastewater to transform livestock wastes and wastewater into fertilizer without separating solid with liquid. The mode has a good many advantages. It can produce organic fertilizer with high quality and return nutrients into fields, which can reduce dosage of chemical fertilizer and pesticide as well as promote the quality of crops. In that sense, it boosts the competitiveness of products, increases added value of crops and also realizes regional ecological circulation of wastes which abate environmental risks. It is a good path to rural circular economy. The technique process sees Figure 11.

south China, the population is dense and many villages are gradually turned into small towns, where centralized treatment for domestic wastewater should be considered.

A 26.1kms long rural sewage pipe network has been constructed in Huancui District, Weihai, Shandong province. Both industrial and domestic wastewater from Wenquan and Caomiaozi town are collected through the network and transport into the Second Wastewater Treatment Plant of Weihai. The effluent meets the discharging standard.

Wastewater treatment plants in dwelling district are successively constructed in Shilu Village Qinsha Village Sanbei Village Danghu Street, Wuyi Village Zhongdai Street, Xincang Town, Pinghu City, Zhejiang Province. The domestic wastewater from more than 400 households is treated by centralized mode. The “three cellular” septic tanks have been popularized in all rural households. Wastewater treatment project in west district has covered 3 blocks. Up to now, totally 57.6kms pipelines and 36.5kms branch pipelines have been constructed, 4 wastewater pump stations have been built and 25 thousand tons of wastewater is collected through the network per day. The sewage pipe network will gradually expand to cover more dwelling district in rural areas. In east district, the treatment capacity of the first phase of centralized wastewater treatment project will be 50 thousand tons per day. Sewage collecting pipe network will cover 6 towns in east district, and will expand to cover dwelling district in rural areas.

In Jiangyin City, Jiangsu Province, for the purpose of enhancing the strength of environment comprehensive management and realizing the target of “centralizing the agriculture to intensiveness, centralizing the corporation to industrial area, centralizing the people to town and centralizing the wastewater to treatment”, a great number of wastewater treatment plants have been constructed in villages and towns. Based on this, the change from “decentralized treatment” to “centralized treatment and centralized control” is realized and the quality of water environment in rural areas is improved fundamentally. Since 2003, within only two years, 27 wastewater treatment plants have been built in villages and towns in the city, and the total treatment capacity has reached 330 thousand tons per day, ensuring that each town has one wastewater treatment plant at least. 7 village-level wastewater treatment plants have been built in Zhouzhuang town, where a lot of industrial enterprises are gathered.

After 1970s, developed countries have basically finished the pollution abatement of point source, the key point of water pollution control and water environment protection is transferring from point source to non-point source, from cities to rural areas, therefore government and science and technology field pay more and more attention to the research and practice of how to improve the water environment in rural areas and to abate non-point pollution source. Japanese government has carried out the “Rural Sewage Project” Since 1973, which mainly provided centralized

treatment for rural domestic wastewater including drainage from rural households and rural administrations. Considering the construction cost, convenience of operation and management and moderate dispersion of drainage so as to decrease the pollution loading to receiving waters, the Rural Sewage Project is mainly composed of minitype projects, whose daily treatment capacity is generally below 10 thousand cubic meters. Up to 2001, diffusion rate of the Rural Sewage Project has reached 71%.

In centralized wastewater treatment, artificial treatment technologies such as activated sludge process and SBR are usually used.

3.4.2. Decentralized ecological treatment system of domestic wastewater in rural areas

Decentralized wastewater treatment system is generally classified as ecological treatment system and artificial treatment system. Ecological treatment system is classified as land treatment system, stabilization pond system and wetland system.

In a land treatment system, the function of soil layer is the purifying media. It is a natural purifying technology with the longest application history and widest application range. Land treatment system include slow infiltration land treatment system, rapid infiltration land treatment system and underground infiltration treatment system. Stabilization pond system is based on bacterial -algal symbiotic system, it includes aerobic pond, facultative pond and anaerobic pond. Wetland treatment system is base on the combined function of soil layer, bacterial -algal symbiotic system and water plants; it includes surface flow wetland and underflow wetland.

3.4.2.1. Slow infiltration land treatment system

In the flood detention area of west of Shenyang Province, a slow infiltration land, covering an area of 700ha, treatment system is constructed, it can be used to treat rural domestic wastewater. The main system of this land treatment system is a piece of rice paddy. The adjusting system, which can adjust the hydraulic loading and pollution loading of the main system, is a piece of woodland composed of pagoda trees and willows. Assistant system includes pre-treatment ponds around, inlet ditches, side infiltration ditches and fish ponds. After sedimentation of pre-treatment, the wastewater first comes into the stem inlet ditch, then, goes through evenly spaced side by side branch ditches and is uniformly distributed into the land field. After being treated, wastewater is discharged through the side infiltration ditches and collected into the outlet ditch and finally comes into the fish pond.

3.4.2.2. Rapid infiltration land treatment system

Attributed to its high pollutants removal rates and high hydraulic loading, rapid infiltration land treatment system gains a wide range of application in China. In Xiaobao, a village in Tongzhou district in Beijing, domestic wastewater is treated by rapid infiltration land system, the processed water can meet the first class discharging

standard. The rapid infiltration treatment system used in Changping district in Beijing is composed of pre-treatment pond, infiltration pond, drainage system, storage pond and so on. The removal rates of COD, SS, total nitrogen and total phosphorus is respectively 91.9%, 98%, 83.2%, 69%.

Cui Lihua and his colleagues conducted a pilot-scale study in the west of Beijing by using artificial soil rapid infiltration (ASRI) treatment system for treating municipal wastewater over a two-year period. The results showed that ASRI treatment system has higher removal rate for municipal wastewater. It did not cause conspicuous accumulation of nitrate and heavy metals in vegetables and rice grain by using the treated effluent for agricultural irrigation. He Jiangtao and his colleagues made some amelioration to the rapid infiltration land treating systems. The hydraulic loading was highly enhanced. Results of the experiment showed that, when the hydraulic loading was enhanced to 2.943m/d, pollutants could still be removed effectively. Removals rates of COD_{Cr} and BOD₅ were 70%~90% and 70%~80% respectively, and those of TN and NH₃-N were 70%~95% and 80%~95% respectively.

Rapid infiltration system has higher hydraulic loading and better purifying effect for treating domestic wastewater. The soil used in the infiltration pond must have good aeration, high activity and high hydraulic loading. If natural soils with these conditions are not available, sand, plant ash and soil can be mixed according to the requirements to make artificial infiltration beds. Generally speaking, in order to renew infiltration speed, after 4 or 5 years operation, the infiltration bed must be cultivated.

3.4.2.3. Underground infiltration treatment system

Underground infiltration treatment system is one of the land treatment technologies. Wastewater, pre-treated by septic tank or hydrolytic acidification tank, goes through underground infiltration ditches under control. It is dispersed by the infiltration effect and capillary effect of soils and then purified by the combined effect of filtration, sedimentation, absorption and bio-degradation. Underground infiltration treatment system has many advantages such as little impact on ground landscape, strong ability to remove nitrate and phosphorus, good effluent water quality which is feasible for reuse, low construction and operation cost, easy management and maintenance, to name a few.

In the national key research project "Rural Non-point Pollution Source Control in Dianchi Drainage Area" Tsinghua University conducted a systematic study on underground infiltration treatment system for the treatment of rural domestic wastewater, developed new type of underground infiltration system and optimized operation conditions and modes for different soil conditions. In the early 2003, an underground infiltration system with treatment capacity of 30-40m³/d was constructed in Taipingguan village, in Dayuxiang, in Chengong county, in Dianchi drainage area. It treated domestic wastewater discharged from 200 households in the

village. Big suspend solids in rural domestic wastewater were first removed by barriers, the water then came into pre-sedimentation tank, adjusting tank, and finally underground infiltration system. During several years of operation, the system displayed stable treatment effect. The removal rates of COD, nitrate and total phosphorus all reached 80-90%, indicating that the effluent quality is better than the quality standard of domestic water issued by Ministry of Construction.

A 6-year operation experience of underground infiltration system in a certain residence zone in Beijing also showed that such system had higher removal rates of organic compounds, nitrate and phosphorus in domestic wastewater. The removal rates of COD, BOD₅, nitrate and TP are greater than 80%, 90%, 90%, 98% respectively.

Underground infiltration system was also applied for treatment of wastewater in the national "863" project "Non-point source pollution abatement in Taihu river network" undertaken by Nanjing University. Wastewater first went into pre-treatment facility (septic tank), supernate in the septic tank then flew into the infiltration ditches. Under control of water supply system, wastewater was dispersed into each infiltration beds through distribution pipe, and went up through soil capillary to the plant root zone. While the nutritious compounds were absorbed by microorganisms and roots, the wastewater was purified.

From the above application cases, it can be learned that underground infiltration treatment system has higher removal rates of pollutants in rural domestic wastewater.

3.4.2.4. Stabilization pond treatment system

The purification principal of stabilization pond is based on bacterial -algal symbiotic system formed in the pond. Algae can photosynthesize under sunshine, fix carbon dioxide, take in nitrate, phosphorus and other organic nutrient compound, and release oxygen simultaneously, which provides appropriate conditions for microorganisms to oxidize and degrade organic compounds. According to the oxygenic conditions, stabilization pond can be classified into aerobic pond, facultative pond and anaerobic pond. The treatment loading of stabilization pond is quite small, therefore it demands larger area and is appropriate in regions with vast land, feasible weather and low soil filtration rate. Recent years, quite a lot cities use stabilization ponds to treat wastewater and gain good effect.

The pilot-scale study of high rate algal ponds conducted by Chen Peng and Xu Chunhua indicated that the average COD removal rate was 75%, BOD removal rate was about 60%, and the average removal rates of nitrate and TP were 91.6% and 50% respectively. The effluent of algal ponds being treated by aquicolous bio-pond, the total removal rates of COD, nitrate and TP were 87.5%, 97.48% and 80% respectively.

Chen Guang and Huang Xiangfeng conducted a pilot-scale experiment on high

rate algal pond system treating rural domestic sewage in Taihu Lake area. The experimental results showed that the average removals of COD, TN, and TP were 69.4%, 41.7% and 45.6% respectively.

3.4.2.5. Wetland treatment System

Wetland is one special kind of transitional ecosystem, which is different from both water and land. It's the overlapping area resulted from the aquatic and land ecosystems stretching to each other. Some artificial measures can be taken to strengthen the removal of pollutants by wetlands, in which process man-made wetlands are constructed to achieve better effects than that of natural wetlands. Man-made wetlands are filled with media that are good at phosphorus adsorption and are better for microorganisms to attach and grow, and at the same time bulrush, zizania aquatica, calamus are grown on the ground. As wastewater runs through wetlands in certain direction, it gets cleaned by the cooperation of soil microorganisms and plants in soil and on surface. There are two kinds of wetlands, including surface flow and undercurrent.

There are some engineering cases in which city sewage is treated by wetlands in China. The first domestic wetland treating system was build up in 1990---Shenzhen Bai Nikeng Wastewater Treating System. Its capability of treatment is 4500m³/d, and the treating place takes an area of 1216mu while the practical usage area is 7146mu. The effluent is able to achieve the 2nd Level of National Discharge Standard for Sewage. In July, 2001, Shenzhen Sha Tian Wastewater Treating plant was put into use, with a treating capability of 5000m³/d and an area of 20000m². Compound vertical man-made wetland is designed by Yue Chunlei and is used for living sewage treatment in one residential area in Zhenhai District, Ningbo. The treating results indicate that wetland has good effects on pollutants removal of sewage. The percentages of removal of NH₄-N, TP, COD, BOD₅ and turbidity reach 80%, and the treated water achieves National Standard for Miscellaneous Water.

Some experiments about the treatment of low concentration rural sewage by man made wetlands are taken by Tsinghua University in Dian Chi. The results indicated that bulrush has a great ability to transfer oxygen, while zizania aquatic perform better in the adsorption of N and P. So bulsh and zizania aquatic should be mixed-planted in order to gain higher percentage of removal of BOD, N and P. Compared surface-flow wetland with undercurrent wetland, bulrush and zizaania aquatic have greater adsorption of N and P in surface-flow wetland than in undercurrent ones, while the removal of COD is reverse. Based on the experiments, a wetland, 3665 m², is built up in Dayu Village, ChengGong Tow, YunNan Province and it can treat the sewage from 287 families in this village. During the rainy seasons, this system is able to treat the first flush, with a capability of 600m³/d. The removal effect of man made wetland for rural sewage is good. The removal percentage of COD is more than 80%, and that of TN, TP are more than 85%, while the average running cost is only 0.03yuan/m³.

3.4.2.6. Other strengthened ecological treatment system

“LIVINGMACHINE” Eco-Treating System: One kind of Eco-Treating System called “LIVINGMACHINE” gets to develop in America, Canada, England and Australia in recent years, which is used for treatment of industrial wastewater and domestic wastewater. Various kinds of animals and plants are designed to get together in this system, to make up for a closed continuously reacting cycle. There are many types of organisms in the reacting tank and reacting pool, including bacteria, algae, plants, fishes, and snails. Nutrients and pathogens are reduced through a series of reactions in this organic entity, and are then digested in a continuous food chain. Wastewater is at first transported to the anaerobic tank underground; and then air is pumped in for a while from the underneath holes. At the same time, $\text{NH}_4\text{-N}$ is degraded into nitrate and after that the wastewater will run into the Bio-Composite Pool. There are a series of sufficient biological compounds, such as algae, single-cell organisms, fishes, aquatic and marsh plants and etc in the pool, where the nutrients in water is degrading furthermore, and flow through underground wetland with wastewater. Nitrates are transformed into N_2 , and wastewater is simultaneously filtrated by roots of plants as well as sands; in which process the wastewater is basically cleaned. The merits of such kind of wastewater treatment system lie in its fineness, serviceable, small size and a low cost.

Earthworm Eco-Filter: It fits to wastewater treatment system with a muster of 50~300 families. Demonstrations are set up by Nanjing University in the countries of Tai River Basin. Septic tank is transformed or used directly, while strengthened ditches take the place of channels and pipelines. The treated water is transported to the Earthworm Eco-Filter. This kind of technology is utilized for rural wastewater treatment, while very good results are obtained.

3.4.3. Diffused artificial treatment system of village rural wastewater

3.4.3.1. Integrated small-scale wastewater purification equipment

Integrated small-size wastewater treatment facility is a combination of pre-treatment, secondary treatment, and advanced treatment, and has many advantages such as small size, stability in treatment, easy to manage and etc. In areas with advanced economic level and higher requirements of wastewater treatment, it has become one of the trends for the development of wastewater decentralized treatment, both domestically and abroad. In Japan, it is early to research the small-size wastewater treatment facility. It is ordained in Japan by the law that purified facility is required in the districts where water-flush toilets are used without sewer system. At present, there are about 8million small-size purified facility in Japan, serving for around 36million people. This technology is more mature in faraway countries lack of sewer systems. Anaerobic filter is often used with contact aeration tank, bio-filter and moving bed contact filter. The picture below shows the Gappei-shori purified facility,

which is widely used in Japan. It is utilized mainly for treating sewage. The BOD of treated water is less than 20mg/L, while TN is less than 20mg/L.

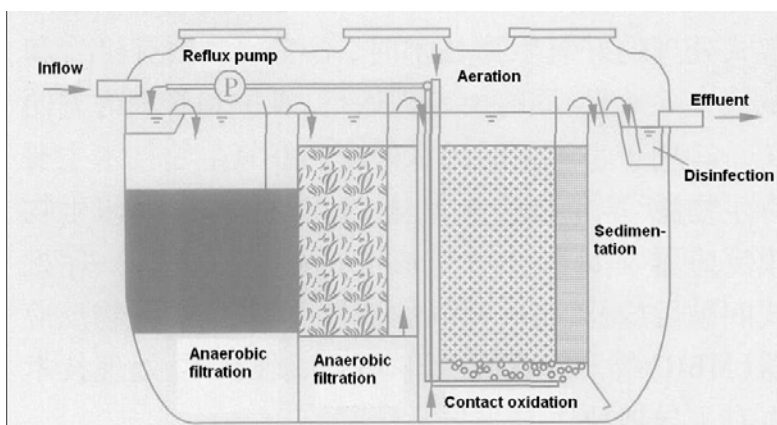

Figure 12 Gappei-shori small-size wastewater purified facility in Japan

Various types of small-size wastewater treating facility are developed by European countries according to their own characteristics. Take Norway as an example: Houses are somehow scattered and many are built on rocks, which makes it impossible to use soil filtration for wastewater; so the integrated wastewater cleaning facilities such as Uponor, Biotrap, and Biovac etc. are developed, mainly relying on SBR, moving bed bio-film reactor, rotating biological contactor and trickling filters, as well as with the combination of chemical flocculation. The percentage of removal for BOD and P is more than 90% by small facilities while that of N is more than 50%. Biovac treating system consists of a cistern and an SBR reactor. The reactor runs intermittently, and wastewater are mixed with sludge for aeration, in which process precipitator $\text{Al}_2(\text{SO}_4)_3$ is added in for the removal of P. The residual sludge will be transported to tanks for sludge dehydration. There are logical control machine and alarming system in Biovac. Uponor is made up of 3 reacting tanks. The former two are used for accumulation of sewage and as a septic tank, while the third one is mainly for the removal of organics, N and P in the terms of combination of SBR and chemical flocculation. BioTrap micro-wastewater treatment system is just a septic tank with a horizontal cylindrical cellar backward. Wastewater is continuously flowing into this treating system. Bio-chemical reactions take place in the former part of this reaction tank. Microorganisms are adsorbed on those tiny cylindrical plastic fillings and are moving together with them, in which process the contact of organics in wastewater and microorganisms are strengthened. The backward part of the reaction tank is used for adding precipitator to remove P and separate solid matter.

Some integrated wastewater treating system mainly using contact oxidation are developed in some parts of China, for treatment of rural sewage and certain effects are obtained.

3.4.3.2. Membrane Biological Reactor (MBR)

MBR is a new and highly efficient wastewater treating technology, which is combined with membrane separation and biological treatment. It's especially suitable for separate wastewater treatment. Compared with other technologies, MBR have many advantages with better and more stable water quality, a higher volume load, a smaller area, a more compact system, less residual sludge, and more convenient to operate and etc. Some small MBR systems are set up in the countries around the Water Source Preservation Districts such as Miyun and Huairou in Beijing, and good results are obtained.

3.4.4. Rural biotoilet and treatment for dejecta wastewater

3.4.4.1. Biotoilet

Biotoilet was first started in Japan and there is no need for water flushing in it. Under the closetool, there is a rectangle tank filled with sawdust as media, and at the same time there is gentle churning up in it. Fermentation of aerobic microorganisms gives out heat and transforms dejecta into non-smelly gases(such as H₂O and CO₂) and dry organic fertilizer. As there is no need for flushing, great amount of water resource is saved. Further more, it's never smelly in the toilets so there is no need for hollow out toilets. Sawdust is somehow a kind of waste and is easy to get, and the reuse as organic fertilizer helps to reduce the pollution of water body.

3.4.4.2. Methane reclaim of dejecta wastewater

Government of Zhejiang Province is actively pushing to popularize the methane reclaim of dejecta wastewater. According to the statistics, 18.7thousands projects for methane reclaim of wastewater are set up all over the province, and very good effects are obtained.

3.4.5. Mode analysis for rural sewage treatment

Conclusions can be made according to cases analyzed above:

(1)At present, researches and practical cases about rural sewage treatment are focused on pollution of organics, N, and P, while little attention is paid to hygienic indices, such as smell, E. coli, insects, maggot and eggs of roundworm. However the hygienic treatment and process to get harmless are the fundamental elements for the reduction of diseases, the improvement of peasants' living quality and rural conditions, and the lessening of difference between country and city.

(2)There are two kinds of systems for rural sewage treatment; one is centralized treatment and the other is decentralized one. Centralized system is suitable when rural families are together and countries are jointed to each other. As wasterwater is converged for treating, it's easier to operate and to maintain the facilities; and as a

result, the treating system is able to run with great stability. However, it's expensive to build pipe lines for districts where families are scattered. In this case, wastewater should be accumulated where it's produced, and is then sent to wastewater treating points nearby. Several treating points may be built according to the landforms. Investment costs will come down given the fact that expenses of pipe lines are lowered. However, special attention should be paid to the operation as treating points are decentralized built.

(3) There are artificial and ecological technologies for treating. Artificial ones have advantages of stability and smaller size, while the costs of construction and operation are somehow larger. Ecological technologies have relatively lower costs but take bigger area and are not so stable.

(4) There aren't specific regulations about treating effects in different districts. We still lack charge standards for wastewater of rural districts.

Some suggestions about rural sewage treatment are given below, generally based on the analysis above:

(1) The theoretical research and case study on the regulations of hygienic indices for rural sewage treating system should be strengthened.

(2) The environment quality standards mainly fit to the cities. Standards that are suitable to rural districts should be set up according to the practical situations.

(3) Accompanying with process of toilets reconstruction, the water sources should be separated if possible. The Black Water and Grey Water should be separated not only to reduce the load of treatment but also to reuse resources and energy efficiently.

(4) The choices of treating systems and technologies for rural sewage should be based on characteristics of different districts: centralized treatment should cooperate with decentralized one while artificial technology should be combined with ecological cleaning technology.

(5) Ecological treating technology should be considered with priority as it has the advantages of low costs and being easy to maintain. However, in order to make sure of the long stable operation, pre-treatment should be adopted. So large amount of suspended solids and lipin can be removed to prevent soil blocking up and sedimentation in the pool. Comprehensive regulations of ecological cleaning system technology should be made.

(6) The treatment can be realized step by step. As the situations differentiated from each other in various rural districts, treating measures should not only be made according to the practical situations, but also can be taken step by step.

3.5. Soil and water conservation in Wuhua County

Wuhua county locates in Hanjiang watershed, a tributary of Zhujiang. It has a land area of 2293 km², and 38% of them (875km²) is threatened by soil and water loss.

3.5.1. Measures and practices

According to causes and characteristics of slope disintegration, engineering technology and forestry and grass practices were adopted and control, protection and management should be integrated. Engineering practices take effect to store water, retain sediments and promote irrigation in short-term. Forest and grass practices will protect soil from erosion, adjust runoff, mitigate flood and improve ecological environment. In this way, engineering practices must be integrated with forest and grass practices to abate erosion. Detail method includes “Retention, Stop and Afforestation”.

Retention construction is to integrate engineering practices with biological practices, and contour trench is commonly used. Contour trench is a ditch from top of hills downside, located above hillside or slope farmland, in which there are several small dams, i.e. so-called “bamboo node ditches”. The contour aims to reduce length of slope and erosion, intercept runoff and make them infiltration, assimilate runoff at the slope and increase soil moisture. At the same time, the contour can protect gully heads, and reduce the erosion for it. At early stage, contour should be maintained carefully and be repaired after each storm to keep the ditch dam in good condition. Otherwise, not only can contour intercept runoff, but it will induce soil erosion and aggravate slope disintegration. Another method of dam is to construct retention ditches, an important drainage engineering on slope, which is generally located on slope or at the foot of slope. The bottom of interception dam should be sloping so as to lead runoff from cropland, forestry into slope water storage, such as brooks and rivers to reduce slope erosion.

Stop construction refers to engineering practices to protect gully from incising and expanding, example of which as sand dam, check dam etc. It is generally located in disintegrated slope and incision gully to retention sands and flood, raise erosion datum plane, reduce relative height difference of disintegrated rock, stabilize slope root, avoid gully incision and extension resulted from erosion, and improve environment of vegetation in gullies.

Afforestation is to locate forestry for water and soil conservation, firewood, economic forestry, arbor, frutex, and grass from slope top to root, on local condition of natural environment and soil. At the same time, slope farmland should be converted into terrace land, or be returned to forestry or grass so as to integrate control with prevention, integrate forest-grass practices with engineering, and integrate protection

with utilization.

Forest-grass oriented control practices is a quick and effective method. Strategically, it is important to plant grass and frutex before forestry in terms of proper layout of grass, frutex and arbor, which accord with succession rule. Basic forestry practices in soil erosion areas to contour mixed planting, which has good performances. Block or strip mixed planting can increase perpendicular distribution patterns and horizontal forestry types hence increase resistance of forestry ecology. Due to poor site conditions and ecology in soil erosion areas, afforestation should be complemented by engineering practices to improve soil moisture. Engineering practices can promote forest and grass which in turn protect the constructed equipments. The combination of technology and forestry practices will intercept and reduce runoff effectively and conserve soil and water effectively.

3.5.2. Benefit

After years of treatment, Wuhua has seen distinct ecological benefit and economic benefit of water and soil conservation, which lies in several aspects below:

Firstly, sands content in rivers has been reduced. Lots of sands retention and water storage engineering and practices, such as sands dam, check dam, contour, and afforestation practices etc. has reduced sands in rivers considerably. For example, sands content of Wuhua river has been reduced by 8.0%-15.9%, and sands content at Hengshan hydrological station in Hanshan began to reduce from the third year and has been reduced from 0.5kg/m³ to 0.32kg/m³.

Secondly, average forest coverage in Wuhua county has been increased by 20% and even higher in prior control regions. For example, forest coverage of Xinqiao Village and Mianyang Village amounts to 67% and 76%, 37.8% and 41.7% higher than before.

Thirdly, soil fertility is increased due to reduction of water and soil loss. Organic matter content in soil has been increased by 50.3%-78%, total nitrogen by 84%. Red soil on Masson's pine slope after 9 years enclosure and protection is 18.25% higher than that after 9 years, and total nitrogen is 10.5% higher.

4 Countermeasures for New Rural Development

4.1. Intensifying policy and funds supports

Given the fact that China's rural area is featured by fragmented residence, small size and low income, the centralized measures for urban development with huge size and high cost can not be adopted for the New Rural Development. Accordingly, the key point of addressing rural environmental problems and sanitation is to develop adaptable measures with low cost to meet the rural conditions and features.

Besides the shortfall of funds, the inefficient and ineffective management of rural area is the fundamental problem for the rural environmental issues of the New Rural Development. It is crucial to establish and develop an effective long-acting mechanism for improving the rural environmental management, which should guarantee sufficient human resource, funds and effective institutions for the New Rural Development. Consequently, the root for addressing environmental issues of the New Rural Development is to strengthen the construction process, as well as to intensify the capacity building and improve management skills, such as rectifying the relations of management system and making clear-definition of functions and responsibilities.

In the meanwhile, it is important to establish an effective mechanism to guarantee the environmental development of the New Rural Development and to optimize and restructure the resource allocation between the urban and rural areas. The local governmental and farmers' manners should be guided through providing appropriate policy supports, such as investment policy, land policy, technical policy and evaluation of political performance; while the environment-friendly practices should be supported and encouraged.

Given the fact that the funds raising, at this moment, is the core for environmental development of the New Rural Development, it is proposed to develop a new mode impelling agriculture through industrial development and promoting the countryside driven by urban development. Furthermore, it is crucial to change the current fiscal policy to guarantee sufficient funds supports for the environmental development of the New Rural Development, creating a new financing mechanism linking the governmental fiscal and capitals of financing market, increasing governmental subsidies and the investment of rural infrastructure and ecological environment, establishing compensation mechanism for protecting rural environment and intensifying the fiscal supports for specific regions (such as ecological fragility, water resource and key environmental function regions), and developing a long-acting financing mechanism by adopting market principles.

4.2. Particular consideration of local conditions

Till the end of 2004, there are totally 19,000 townships, 20,000 towns, 63 administrative villages and 2,530,000 natural villages in China with a rural population of 760 million. Given the fact that the rural areas are distributed widely and scattered in China and featured by diverse economic and social development, natural and ecological environment, cultures and environmental problems in different geographic regions, it is crucial to adopt adaptable measures for promoting the New Rural Development in different towns and villages according to the local conditions such as economic, social, geographic, environmental, resources, education, and etc.

4.3. Priority of drinking water and public sanitation improvement

To develop and improve the drinking water safety and rural sanitation environment is the most prior environmental issues that need to be solved in the New Rural Development, the most important measures to increase life, decrease diseases, improve living condition, improve labor quality of rural residents, the basis of increasing survival rate and production of livestock, and improve relevant products' quality, and the basis to increase income of farmers and boost village industries. It is called to promote local government to conceive strategy and planning, and to finally establish a drinking water standard and public sanitation standard close to those of cities.

4.4. Focus on farmers' awareness and respect of their willingness

Farmers are not only the main actors but also the beneficiaries of the rural environmental development and improvement. Thus, it is essential to pay increasingly attention on the social problems for the New Rural Development. Firstly, it is requisite to respect the farms' will and stimulate their enthusiasm and creativities to participate in the rural reconstruction activities as deciding the development plans, constructing infrastructures and other facilities (such as water supply, sewers, power, communication, and etc.). The governments should encourage and support the farmers to formulate a new self-governance replacing the tradition of monopolized governmental management. Secondly, the implementation of the New Rural Development should be accordance with local culture and custom, resource characteristics and house features. The conducted measures should be selected in terms of the exact requirements of farmers and local cultural features, as well as be taken up by the farmers.

4.5. Full understanding of current account and targeted development

The reasons causing current undeveloped economy and worsened environment of Chinese rural regions should be traced back to a long historical background. It also shows that the process of rural reconstruction can not be a quick action but a long-term progressive fight. Firstly, the fact of unbalanced rural development brings out that the New Countryside Building has to be conducted by various means in different regions according to the local development level and actual demands, setting the appropriate targets, giving prominence to the key point and implementing progressively. Secondly, the New Countryside Building can not be accomplished in one action by campaigns but a long-term project. In the meanwhile, it is proposed to

accelerate the rural reconstruction pace in coastal and some developed regions.

On the other hand, the countryside housing in China is always characterized by dispersiveness and randomness, which is also one of major reasons causing the rural untidiness. It is reported that only 24.9% towns and villages in China have development plans and 75% towns, 95% administrative villages and 98% natural villages lack of basic planning materials such as topographic maps. The unplanned development is a major reason resulting in the messed rural distribution featured by scattered, small-size and disorder. According to Chinese Agricultural University, 99% villages have no plans for infrastructure and public utilities in 2005. Thus, it is principal to make an integrated and systematic environmental plan for the New Socialist New Countryside Building, defining the direction and principles of development, setting the targets and providing policy supports. Then, it should be reminded that the rural development plans should be made by specific measures, avoiding the mechanical copy of urban planning. Thirdly, the integrity and system have to be stressed in the plans of New Countryside Building. The construction of rural infrastructure and the design of landscape and houses should be harmonious with the natural environment.

4.6. Utilization efficiency and profit improvement

The utilization efficiency of rural biomass is quite low in China and it is just at the early stage of development for recycling crop straws and livestock manure. The current utilization efficiency of fertilizer is only 32-35% in China, which is much lower than the one of developed countries (50-60%) and has caused a great amount of N, P run off to the environment. The mulching film is used widely in China, but about 20% films are remained in the land and lead to soil pollution. Furthermore, there are about 650 million ton crop straw generated every year in China, 60% of which can not be used effectively but to be dumped or incinerated on-site. This has caused serious environmental pollution and energy waste. On the contrary, it is reported that about 150 million farmers were facing fuel shortage and over 240 million farmers were cooking with firewood in 2004. The utilization efficiency of heat can only reach 10%. Hence, it is called to extend the chain of agricultural production; to develop effective and high efficient energy technologies and devices and make good use of local resource and renewable energy; to facilitate the recycle of rural resource; and etc.

4.7. Focus on low-cost measures and technologies

In 2005, the average net income of farmers is 3255 RMB per capita, equaling to 31% of urban residents; the expenditure of state revenue for “agriculture, countryside and farmers” is 297,500 million RMB, which is about 14.7% of the total expenditure of state revenue; and the ratio of rural fixed asset investment to total fixed asset

investment has decreased by years during the 10th Five Years to 15.2%. Accordingly, taking into account the limitation of national investment and rural family budgets, the construction of environmental infrastructures should adopt and promote the technologies and devices with low-cost and high outcome, improving the efficiency of governmental investment and avoiding increasing the farmers' burdens.